

# User Guide

## Arcadia Central Station User Guide



Part Number: PUB-00021 Revision A

July 08, 2021

# Document reference

---

Arcadia Central Station User Guide

Part Number: PUB-00021 Revision A

Legal disclaimers

Copyright © 2021 HME Clear-Com Ltd

All rights reserved

Clear-Com, the Clear-Com logo, and Clear-Com Concert are trademarks or registered trademarks of HM Electronics, Inc.

The software described in this document is furnished under a license agreement and may be used only in accordance with the terms of the agreement.

The product described in this document is distributed under licenses restricting its use, copying, distribution, and decompilation / reverse engineering. No part of this document may be reproduced in any form by any means without prior written authorization of Clear-Com, an HME Company.

Clear-Com Offices are located in California, USA; Cambridge, UK; Dubai, UAE; Montreal, Canada; and Beijing, China. Specific addresses and contact information can be found on Clear-Com's corporate website: [www.clearcom.com](http://www.clearcom.com)

## Clear-Com contacts:

Americas and Asia-Pacific Headquarters

California, United States

Tel: +1 510 337 6600

Email: [SalesSupportUS@Clearcom.com](mailto:SalesSupportUS@Clearcom.com)

Europe, Middle East, and Africa Headquarters

Cambridge, United Kingdom

Tel: +44 1223 815000

Email: [SalesSupportEMEA@Clearcom.com](mailto:SalesSupportEMEA@Clearcom.com)

China Office

Beijing Representative Office

Beijing, P.R. China

Tel: +8610 59000198/59002608

Email: [salesupportAPAC@ClearCom.com](mailto:salesupportAPAC@ClearCom.com)

# Table of contents

---

1 Introduction .....	6
1.1 Product Features .....	7
1.2 Arcadia Central Station Interconnections .....	9
2 Upgrading Licenses .....	10
2.1 Introduction .....	11
2.2 Online Upgrading of Port Capacity .....	12
2.3 Offline Upgrading of Port Capacity .....	13
3 Installing Arcadia Central Station .....	17
3.1 Front Panel Connectors, Controls and Indicators .....	18
3.2 Intercom Touchscreens .....	20
3.3 Rear Panel Connectors and Indicators .....	22
3.4 System Powering .....	24
3.5 Clear-Com Ethernet Cable Recommendations .....	25
3.6 Stage Announce and Program Feed .....	26
3.7 Setting the Management IP Address .....	26
3.8 Saving and Restoring System Configuration .....	28
3.9 Resetting to Default .....	29
4 Introduction to the CCM .....	30
4.1 Accessing the CCM .....	32
4.2 Changing the CCM Password .....	33
4.3 Hardware Page Overview .....	34
4.4 Configuration Page Overview .....	35
4.5 Status Page .....	39
5 Example Applications .....	40
5.1 Fast and Easy Setup: E1 .....	41
5.2 Using E1 With Six Transceivers .....	43
5.3 Using IP Transceivers with the Arcadia Central Station .....	45
5.4 Split Frequency Setup (5, 2.4 and 1.9 GHz System) .....	47
6 Connecting Transceivers .....	48
6.1 Overview of Transceivers .....	49
6.2 Connecting Transceivers Over E1 .....	50
6.3 Connecting Transceivers Over IP .....	54
7 Network Setup .....	55

7.1 Network Setup for IP Transceivers .....	56
7.2 Arcadia Central Station LAN Configuration Rules .....	61
<b>8 Connecting to other systems .....</b>	<b>62</b>
8.1 Connecting 2-Wire Systems .....	63
8.2 Connecting 4-Wire Systems .....	66
8.3 Connecting to Dante-Enabled Devices .....	70
<b>9 Configuring from the CCM .....</b>	<b>73</b>
9.1 Configuring Station Settings .....	74
9.2 Adding IP Transceivers (FS Edge, FS II 1.9) .....	79
9.3 Registering Beltpacks .....	80
9.4 Channels and Groups .....	82
9.5 Managing Channels .....	84
9.6 Managing Groups .....	88
9.7 Creating and Editing Roles .....	94
9.8 Setting up GPIOs and Logic Events .....	99
9.9 Monitoring System Status .....	102
<b>10 Security .....</b>	<b>109</b>
10.1 Warning .....	110
10.2 Introduction .....	110
10.3 Using Security Certificates .....	111
10.4 Forcing HTTPS .....	112
<b>11 Configuring from the Front Panel .....</b>	<b>114</b>
11.1 Introduction to Configuring from the Front Panel .....	115
11.2 Front Panel Menus .....	116
11.3 Passwords, Addresses and Reset to Default Settings .....	120
<b>12 Upgrading Firmware .....</b>	<b>122</b>
12.1 Introduction .....	123
12.2 Upgrading using the CCM .....	123
12.3 Upgrading using a USB stick .....	123
<b>13 Spare parts .....</b>	<b>125</b>
<b>14 Front Panel Menu Reference Tables .....</b>	<b>126</b>
14.1 Audio Settings .....	127
14.2 Host Settings .....	127
14.3 2 W Audio (A/B) (C/D) .....	128
14.4 Discovery .....	128

14.5 Transceiver .....	129
14.6 Networking .....	130
14.7 Administration .....	131
<b>15 Specifications .....</b>	<b>133</b>
15.1 Arcadia Central Station .....	134
15.2 Capacity .....	137
15.3 Frequency Response - Station to Beltpack .....	137
15.4 Front Panel Headset Microphone .....	138
15.5 Network Specifications .....	139
<b>16 Pinouts .....</b>	<b>141</b>
16.1 GPIO pinouts .....	142
16.2 2-Wire Pinouts .....	143
16.3 4-Wire Pinouts .....	144
16.4 DECT Sync .....	144
<b>17 Regulatory Compliance (Regulatory Model: 1410) .....</b>	<b>145</b>
17.1 FCC Notice .....	145
17.2 FCC/IC/EC RF Exposure Warning .....	146
17.3 Industry Canada Compliance Statement .....	146
17.4 Korean Notice .....	146
17.5 European Union (CE mark) .....	147
17.6 United Kingdom (UKCA Mark) .....	147
17.7 Electrical and Electronic Equipment (WEEE) Waste .....	148

# 1 Introduction

---

This chapter provides an overview of the Arcadia Central Station. It contains the following sections:

- 1.1 Product Features ..... 7
- 1.2 Arcadia Central Station Interconnections ..... 9

---

## 1.1 Product Features

The Arcadia Central Station is an IP-based standalone 1RU device supporting wired and wireless endpoints with up to 96 total ports of connectivity, 64 of which are available for Dante/AES67. Flexible licensing of features - including ports - allows Arcadia to expand over time as needed, making it a future-proof investment. For more information, refer to the [Arcadia Knowledge Center](#).



[www.clearcom.com/arcadia-knowledge-center](http://www.clearcom.com/arcadia-knowledge-center)

Arcadia Central Station supports:

- 16 IP transceivers (any combination up to a total of 16 of FreeSpeak II and FreeSpeak Edge TCVRs)
- 10 E1 transceivers (any combination up to a total of 10 of FreeSpeak II 1.9 and 2.4 TCVRs)
- 32 wireless beltpacks (any combination up to a total of 32 of FreeSpeak II and FreeSpeak Edge beltpacks)
- 64 Dante channels
- Eight 4-wire ports
  - Port 8 is dedicated to program feed and stage announce
- Four 2-wire ports (Clear-Com or RTS)

The secure browser-based Core Configuration Manager (CCM) offers intuitive configuration and you also have the option of using the touch-sensitive front-panel screens.

You can connect the Arcadia Central Station to:

- Wireless transceivers:
  - 1.9 GHz - E1 or IP connection
  - 2.4 GHz - E1 only
  - 5 GHz - IP only
- 2-wire and digital partyline systems such and Encore
- Dante compliant systems

System limits:

- 100 channels
- 100 groups
- 200 roles



## 1.2 Arcadia Central Station Interconnections

The following graphic shows an overview of how the Arcadia Central Station can interconnect with other intercom components.

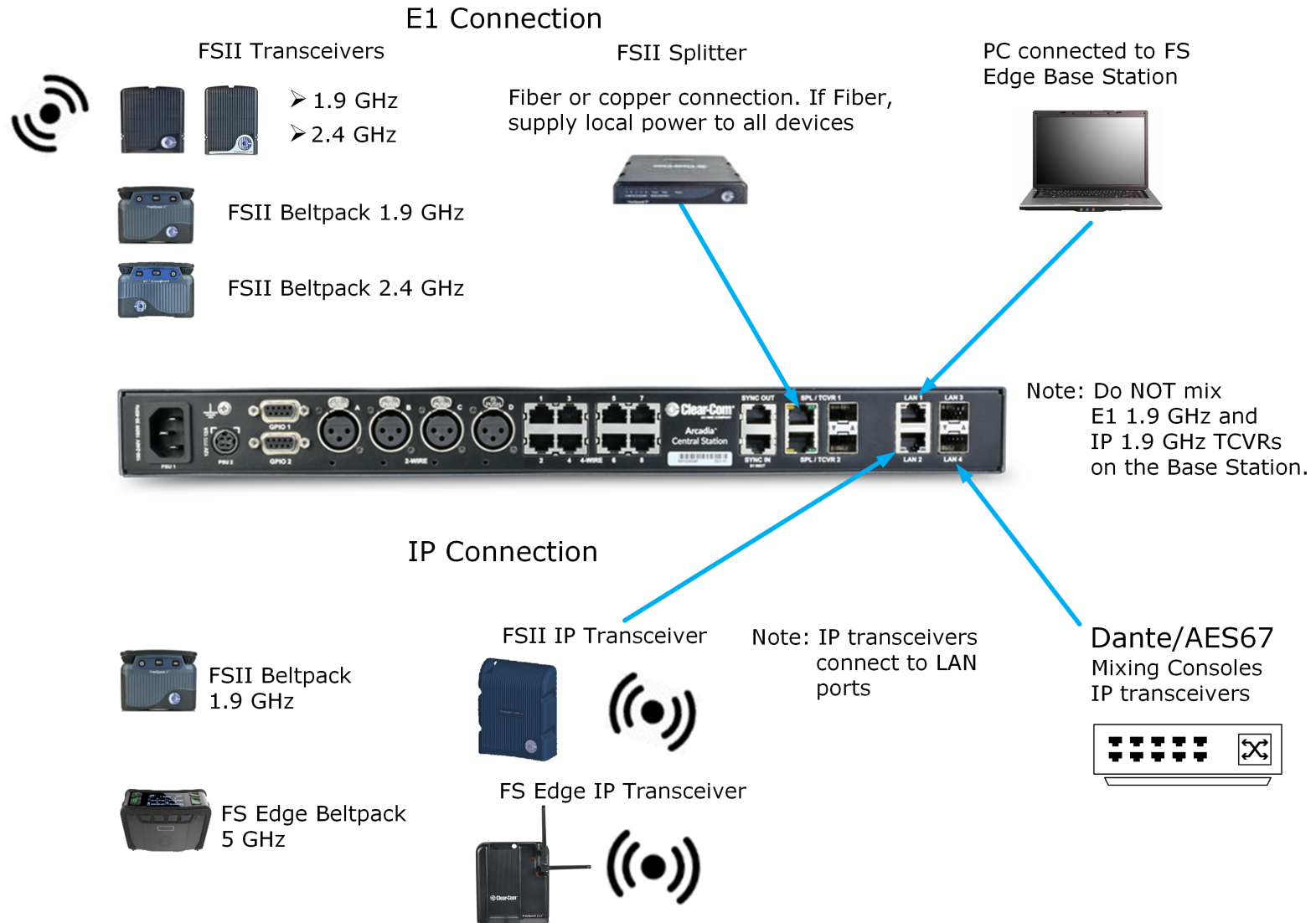

# 2 Upgrading Licenses

---

This chapter describes how to upgrade your Arcadia Central Station license. It contains the following sections:

- 2.1 Introduction ..... 11
- 2.2 Online Upgrading of Port Capacity .....12
- 2.3 Offline Upgrading of Port Capacity .....13

---

## 2.1 Introduction

The Arcadia Central Station is available with several licensing options:

- 32 ports
- 48 ports
- 64 ports
- 80 ports
- 96 ports.

You can purchase additional port capacity in 16-port bundles to a maximum of 96 ports.

The additional 16-port bundles can be used for beltpacks and Dante connections (up to 32 beltpacks and 64 Dante ports).

Additional 16-port bundles are available from your Clear-Com dealer. When you purchase additional port bundles, Clear-Com will send you a code for your licenses that can be activated in the CCM of your Arcadia Central Station.

For more information about licensing, refer to the [Arcadia Knowledge Center](#).



[www.clearcom.com/arcadia-knowledge-center](http://www.clearcom.com/arcadia-knowledge-center)

## 2.2 Online Upgrading of Port Capacity

**Note:** You can *ONLY* upgrade online if your PC and Arcadia Central Station have an Internet connection on the same network.

1. Navigate to **Hardware > Resources > Host > License**, and select **Add licenses online**.

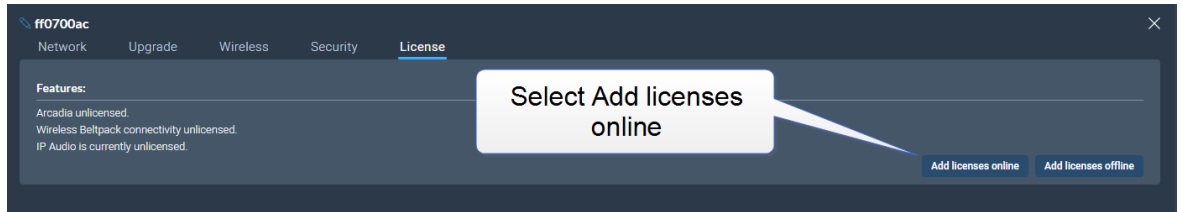

2. Enter the ticket you received from Clear-Com, and then select **Validate**.

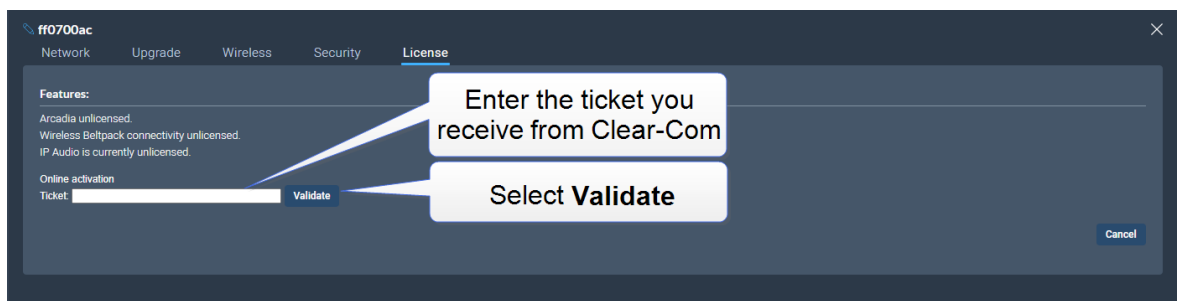

3. Click the checkbox, select the quantity of 16-port bundles you wish to install and click **Activate**.

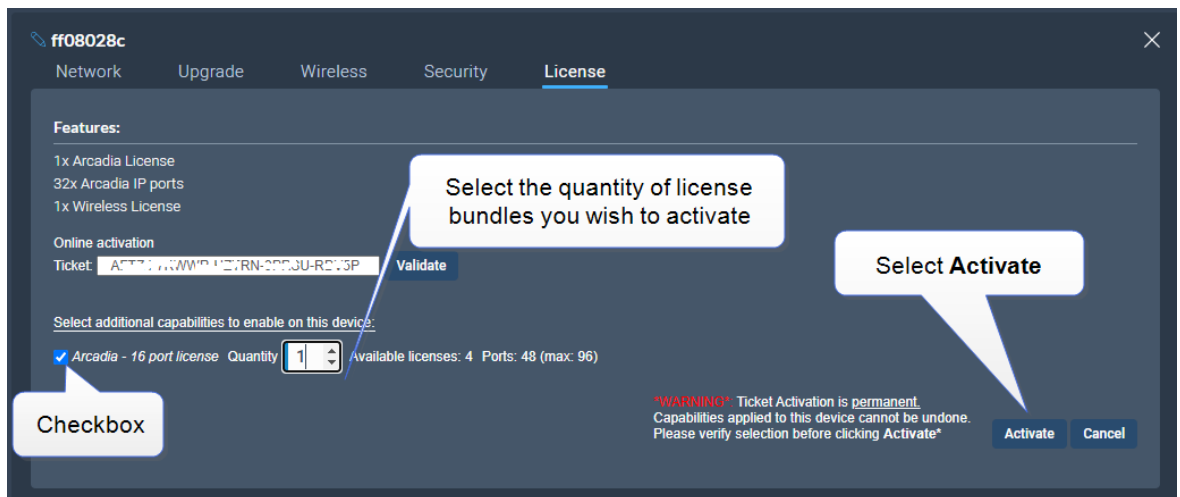

4. You must reboot the Station before the licenses take effect. In the CCM, navigate to **Status > Overview > Host Device** and select **Reboot**.
5. Once the licenses are activated, you will be able to see how many licenses you have in the **Hardware > Resources** page under **Licensed Ports**.

## 2.3 Offline Upgrading of Port Capacity

1. Navigate to **Hardware > Resources > Host > License**, and select **Add licenses offline**.

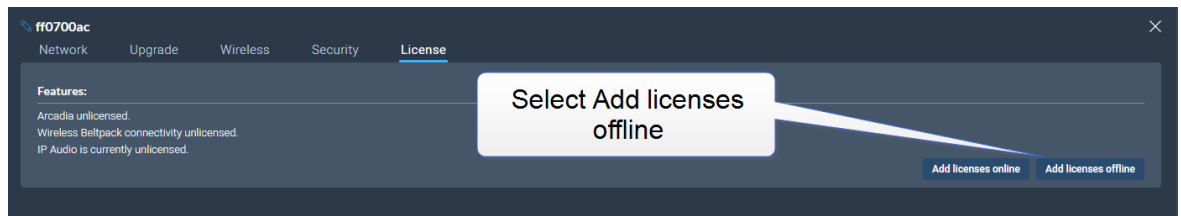

2. Select **Get Context File**.

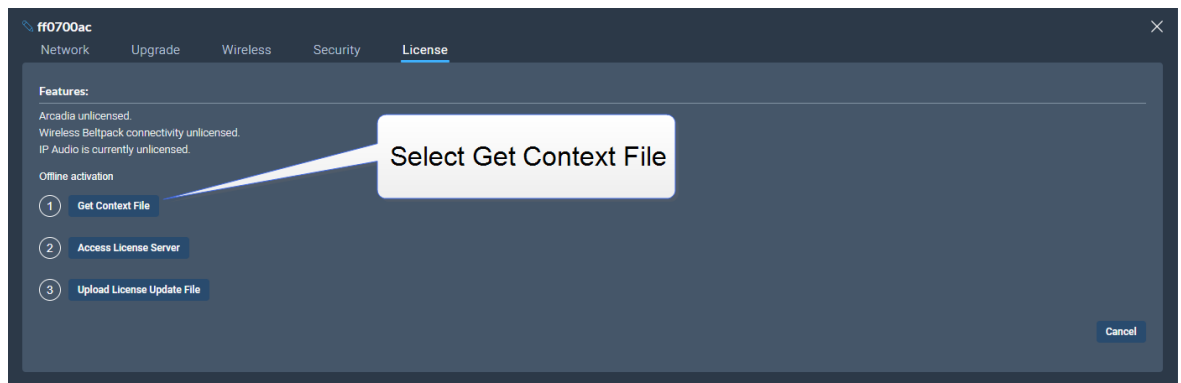

The context file downloads locally.

3. Click on **Access License Server** if the local PC has access to the internet. This will open a new tab in the browser connecting to the license server. Otherwise, use another PC which has internet access and connect a browser to <http://license.clearcom.com:8080/webdepot/>. As you will download the licenses into the previously downloaded context file (step 2) you need the context file on the new PC.
4. You will see the online license server. Enter your Clear-Com ticket number, and then Click **Next**.

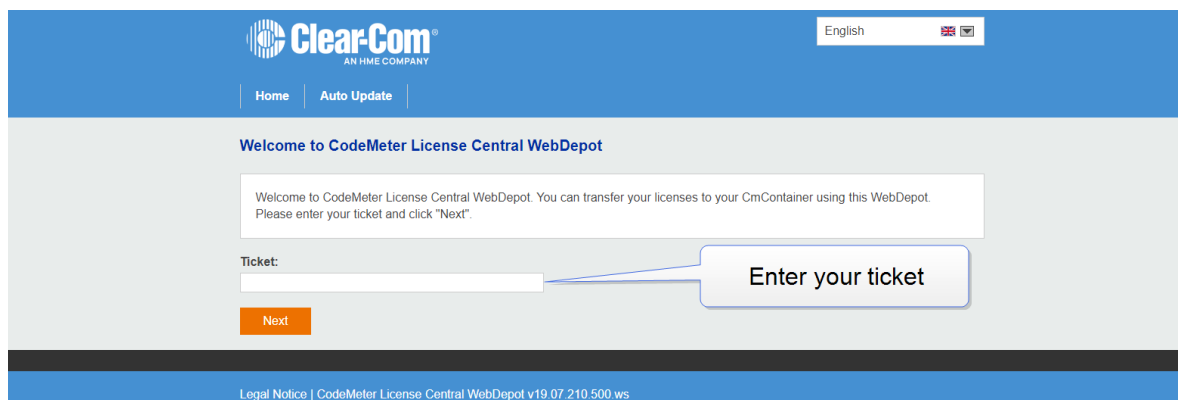

5. The licenses on your ticket are displayed on the screen. Select **Activate Licenses**.

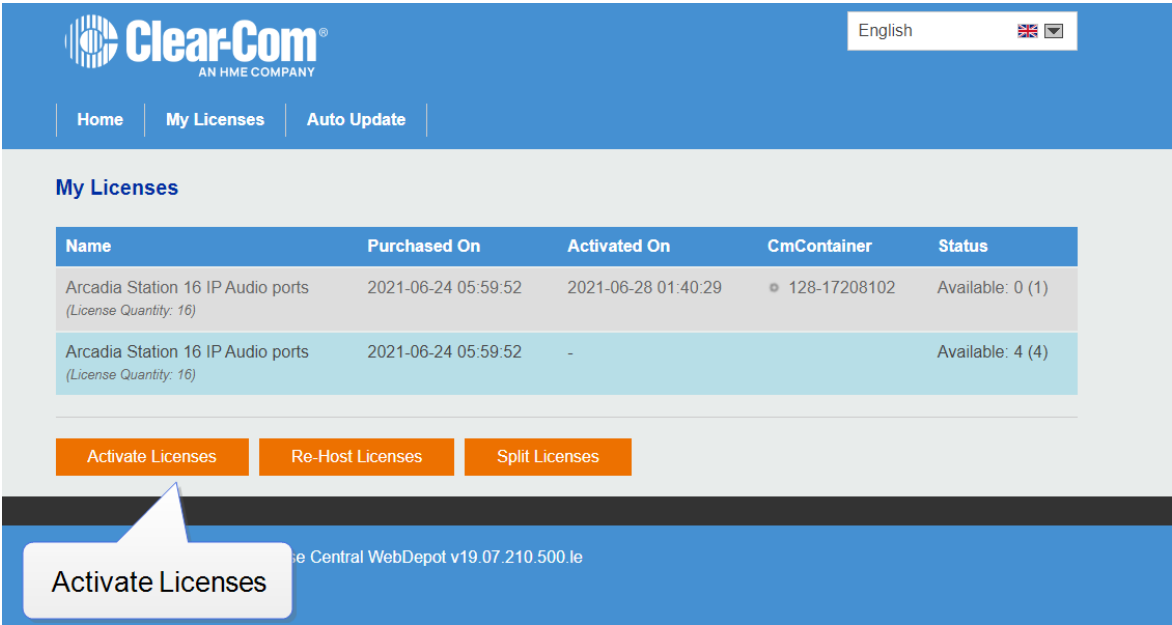

6. Select the left-hand option.

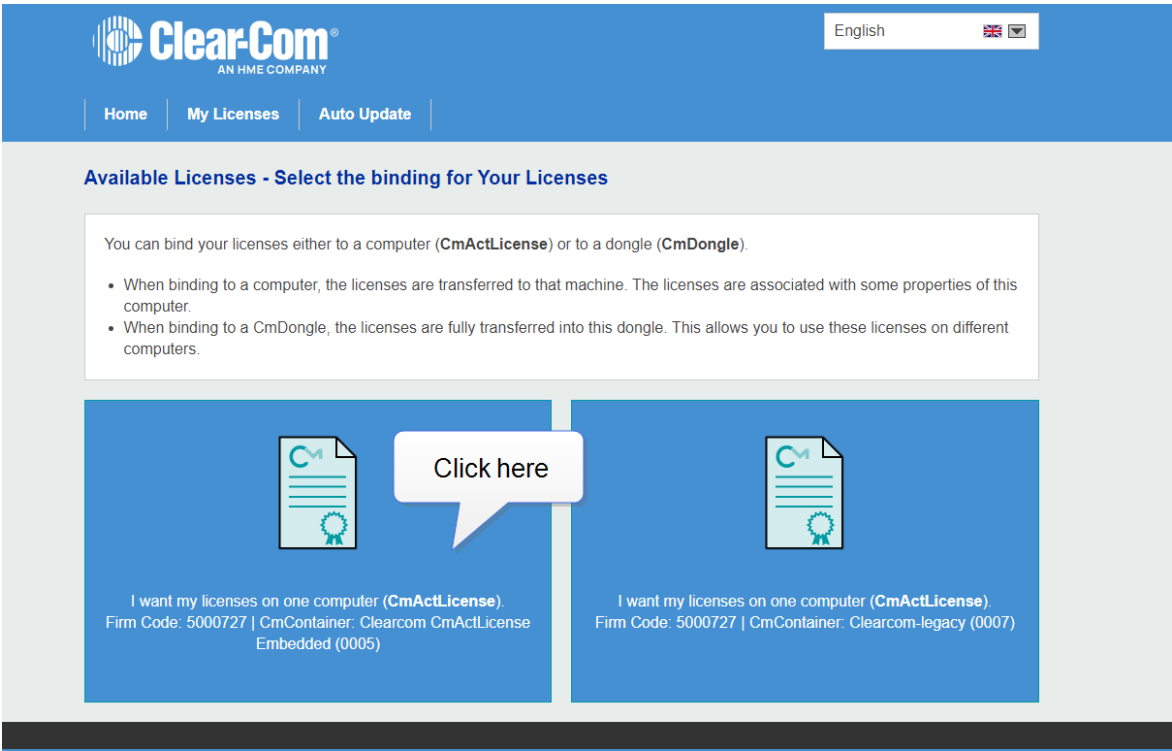

7. Click **File-based license transfer**.

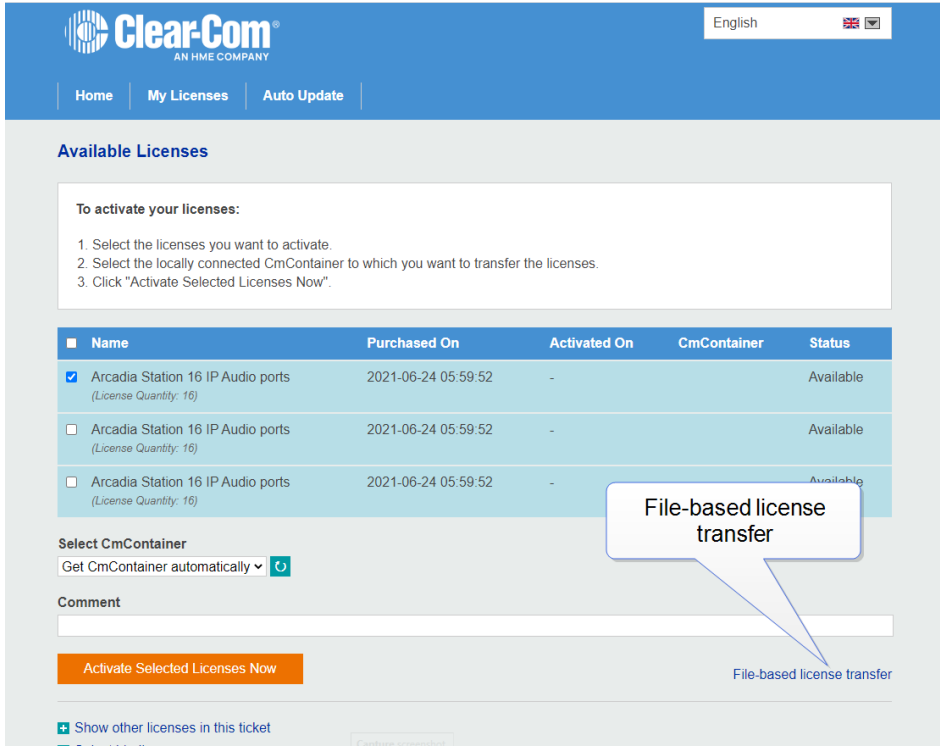

8. Select the required license(s). Click Choose File and navigate to the context file (downloaded in step 2). Select it. Then click **Start Activation Now**.

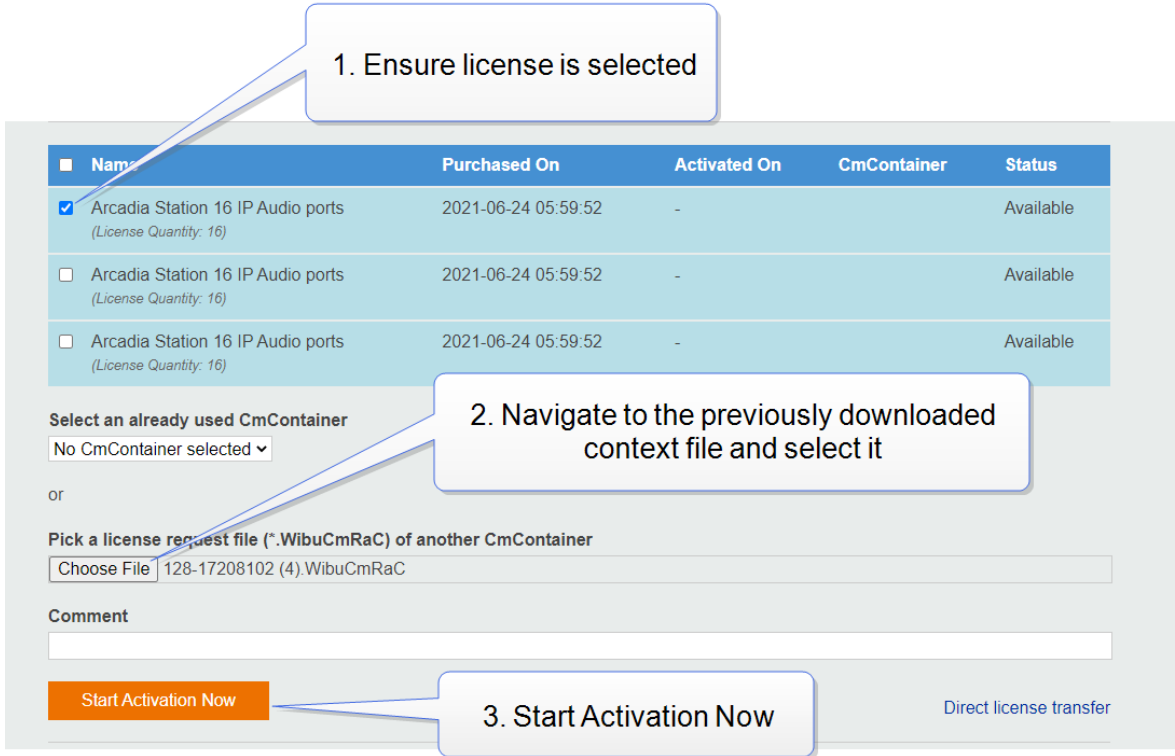

- Download the License Update File
- Note:** Do not **Upload Receipt Now**. Instead, return to the CCM and select **Upload License Update File**.

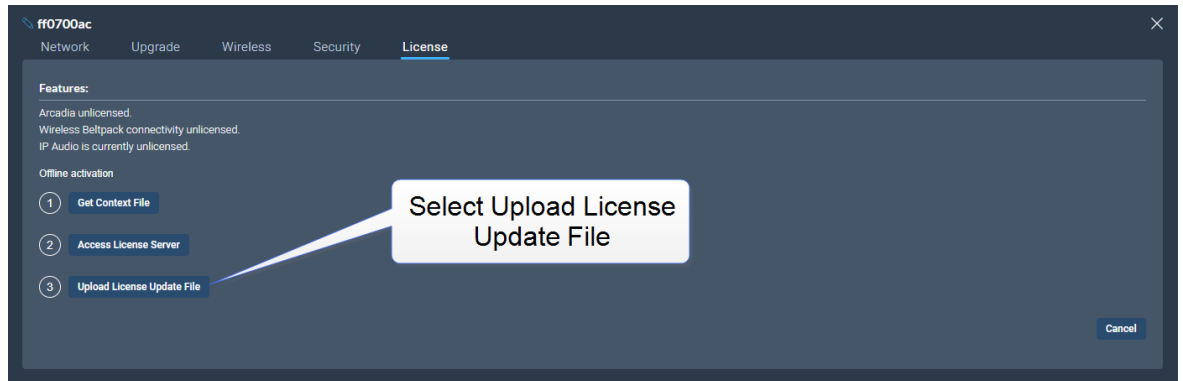

- Navigate to where you have stored the downloaded file from Step 9. The file is labeled 'Wibu- Systems Codemeter Receipt File'. Select the file. The license will upload.
- You must reboot the Station before the licenses take effect. In the CCM, navigate to **Status > Overview > Host Device** and select **Reboot**.
- Once the licenses are activated, you will be able to see how many licenses you have in the **Hardware > Resources** page under **Licensed Ports**.



# 3 Installing Arcadia Central Station

---

This chapter describes the front and rear panels, power supplies and cabling recommendations. It also describes network setup and illustrates example applications. It contains the following sections:

- 3.1 Front Panel Connectors, Controls and Indicators ..... 18
- 3.2 Intercom Touchscreens ..... 20
- 3.3 Rear Panel Connectors and Indicators ..... 22
- 3.4 System Powering ..... 24
- 3.5 Clear-Com Ethernet Cable Recommendations ..... 25
- 3.6 Stage Announce and Program Feed ..... 26
- 3.7 Setting the Management IP Address ..... 26
- 3.8 Saving and Restoring System Configuration ..... 28
- 3.9 Resetting to Default ..... 29

---

### 3.1 Front Panel Connectors, Controls and Indicators

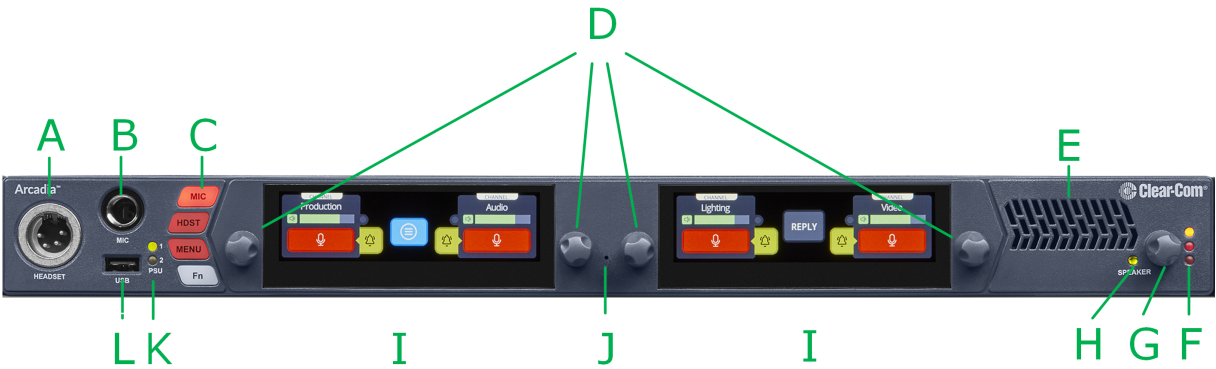

The FreeSpeak Arcadia front panel connectors, controls and indicators are listed below.

Item	Description
A	Headset connector (4-pin or 5-pin XLR).
B	Gooseneck mic socket (1/4-inch jack)
C	<p><b>Mic:</b> when a headset is connected, this button switches audio between the headset mic and the gooseneck mic.</p> <p><b>HDST:</b> when a headset is connected, this button switches the headset microphone output to the loudspeaker.</p> <p><b>Menu:</b> Press to enter menu mode. Press again to exit, or allow menu mode to time out.</p> <p><b>Fn:</b> Function button. No functions currently available.</p>
D	Rotary Encoders. Use these to control channel volume or to navigate through the menu system.
E	Loudspeaker
F	<p>Main Volume Level LEDs:</p> <ul style="list-style-type: none"> <li>• Red - high volume level</li> <li>• Amber - medium volume level</li> <li>• Green - low volume level</li> </ul>
G	Main Volume Control
H	Speaker active LED
I	Color touchscreen displays
J	Pin reset
K	Power Supply Unit LEDs
L	<p>USB A connector. Use to:</p> <ul style="list-style-type: none"> <li>• Register beltpacks</li> <li>• Upgrade the Arcadia Central Station</li> <li>• Save/Restore system settings</li> <li>• Obtain detailed logs for diagnostic purposes</li> </ul>

## 3.2 Intercom Touchscreens

The Arcadia Central Station has two intercom control touchscreens, available when the front panel screens are not in menu mode. Each touchscreen provides access to two keys which can be configured for channels, groups or point to point communications channels.

### 3.2.1 Left Intercom Touchscreen

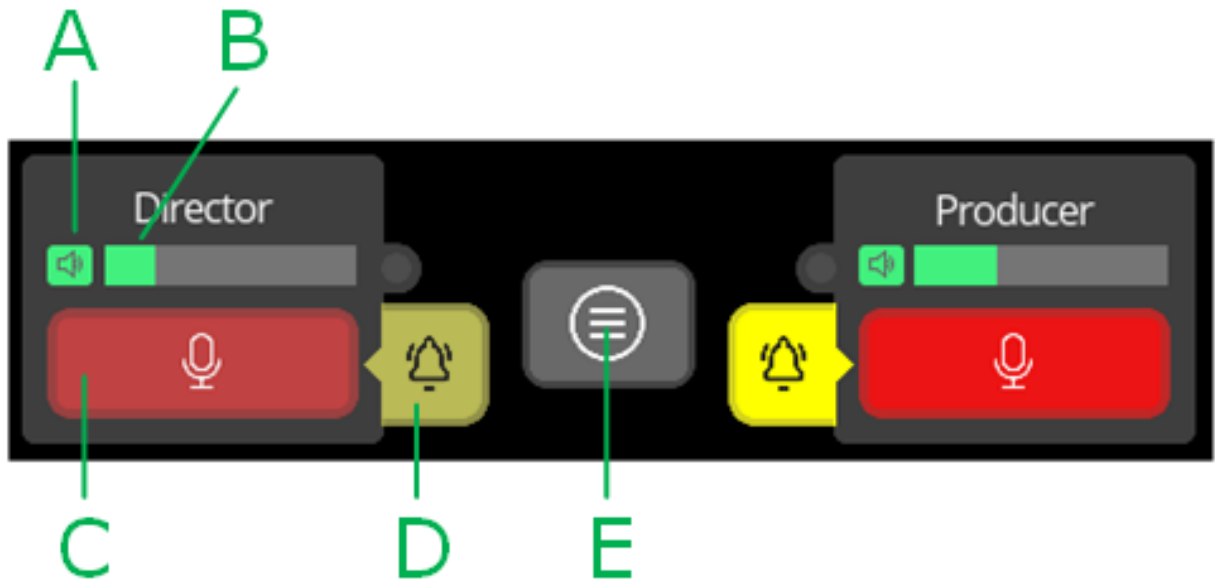

Item	Description
A	Listen activation indicator.
B	Volume level indicator. Control the volume with the rotary controller next to the channel/audio source.
C	Talk button.
D	Call button. Use this to send a call signal.
E	Menu button. Touch to see: <ul style="list-style-type: none"> <li>• Stage Announce</li> <li>• All talk</li> <li>• Remote mic kill (RMK)</li> </ul>

### 3.2.2 Right Intercom Touchscreen

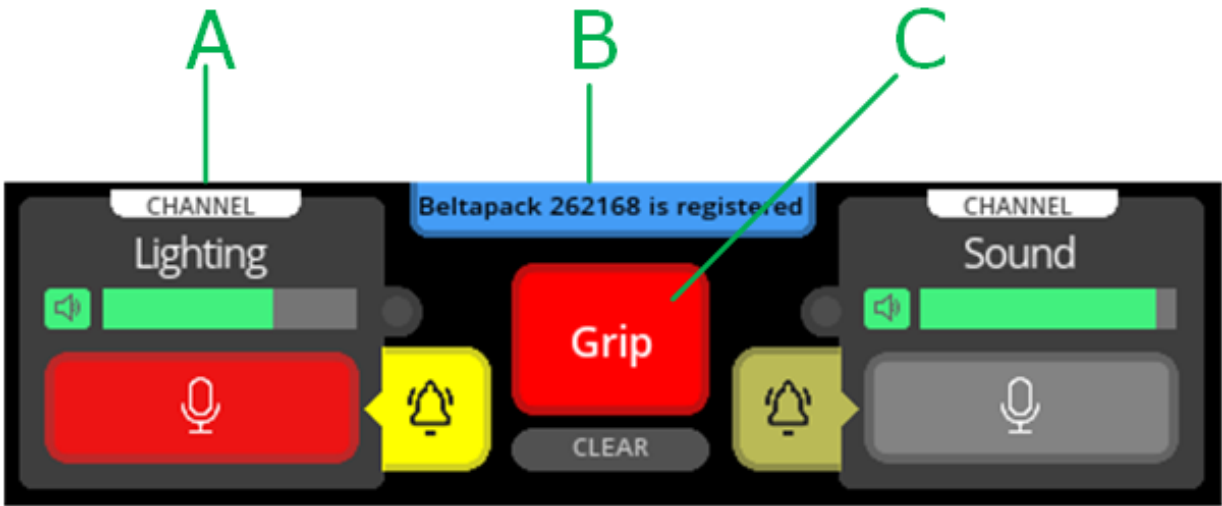

Item	Description
A	Channel indication. Audio routes can be point-to-point or channels.
B	Notification bar <ul style="list-style-type: none"><li>• Beltapack registration</li><li>• Progress of upgrades</li><li>• Support information gathering</li><li>• Resoration of configuration progress</li></ul>
C	Reply button. Use CLEAR to clear the currently visible entry (does not clear the entire key stack).

### 3.3 Rear Panel Connectors and Indicators

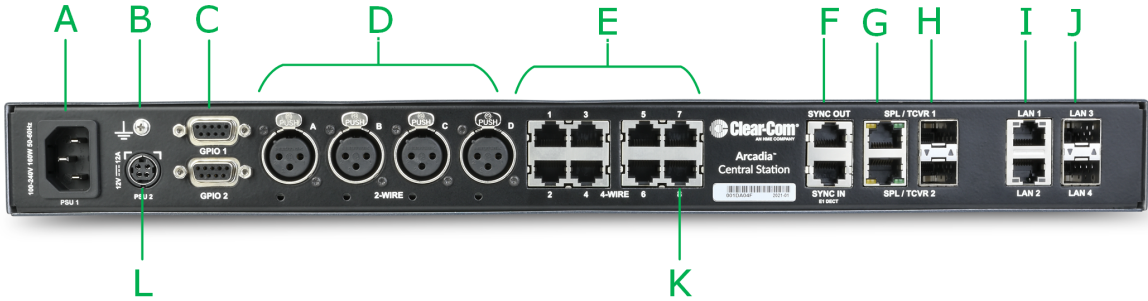

The FreeSpeak Arcadia rear connectors and indicators are listed below.

Item	Description
A	Internal power connector. Mains power lead with internal power supply.
B	Grounding screw.
C	General Purpose Input/Output connectors x2 (DB-9F). <ul style="list-style-type: none"> <li>• GPIO 1 hosts GPI1 and GPO1 &amp; 2</li> <li>• GPIO 2 hosts GPI2 and GPO 3 &amp; 4.</li> </ul>
D	XLR 2-wire Partyline connectors (standard microphone cable)
E	RJ45 4-wire audio and data connectors. Port 8 is dedicated to Program Feed ( <b>PGM</b> ) and Stage Announce ( <b>SA</b> ), to be used with the split XLR cable connector that is supplied with the Arcadia Central Station.
F	Dect Sync RJ45 connectors, IN, OUT.
G	E1 RJ45 connectors to splitter/transceiver. Do not connect IP transceivers here.
H	SFP cage for E1 fiber connection to splitter/transceiver. Either single-mode or multi-mode fiber modules. Modules must match existing cabling. Do not connect IP transceivers here.
I	RJ45 LAN connectors. IP transceivers, the configuration PC and Dante are connected here. Capacity 1Gb.
J	SFP cage for fiber LAN connectors. Capacity 2.5Gb.
K	SA/PGM
L	External power supply connector. <b>CAUTION:</b> Before using, see <a href="#">System Powering on page 24</a> .

## 3.4 System Powering

There are two power supplies:

- Mains power connector (IEC) internal power supply
- DC connector. External AC/DC power adapter  
12V DC, 12A

Use one power connector, or both to guard against one failing.

### 3.4.1 Using the External DC Power Connector

**CAUTION: YOU MUST CONNECT THE EXTERNAL DC POWER SUPPLY IN THE ORDER DESCRIBED AND ILLUSTRATED BELOW:**

**1.** Connect the external power supply 12V cable connector (**A**) to the rear chassis 12V input connector of the Station.

**Note:** When connecting the power cable, be sure to push until the connector locks into the device.

**2.** Connect External Power Supply mains cord (**B**) to the AC input source.

Station (rear, left-side)



Mains connector

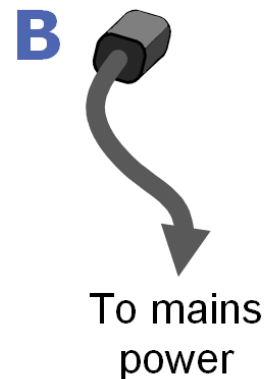



## 3.5 Clear-Com Ethernet Cable Recommendations

Cable recommendations	
Category (Cat)	<p>Higher Cat numbers will support a higher bandwidth. Therefore, by using a higher Cat number you are future proofing your system to some extent. Example:</p> <ul style="list-style-type: none"> <li>• Cat 5e : up to 1 GB</li> <li>• Cat 6: up to 10 GB</li> </ul> <p>Use Cat 5e or higher.</p>
American Wire Gauge (AWG)	<p>The lower the AWG number, the less temperature rise there will be in the cable when using PoE. This is particularly important for bundles. Local building regulations may rule out the use of 26 AWG or higher, depending on the installation. Check with your local building regulations. Use AWG 24 or lower.</p>
Shielded Twisted Pair (STP) or Foiled Twisted Pair (FTP)	<p>Using shielded cable means less problems with interference from other sources. This means that your installation will be more robust if you use shielded cables.</p>

**Note:** Overall recommendation: Use Cat 6a, 23 AWG STP cable.

## 3.6 Stage Announce and Program Feed



Your Arcadia Central Station is supplied with an RJ45 connector that uses a splitter cable to split into two XLR connectors. If you wish to use an external Stage Announce (**SA**) and Program Feed (**PGM**), you must connect this to the RJ45 port labeled **SA/PGM** (port 8) on the rear of your device, and connect your input (**PGM**) and output (**SA**) to these connectors.

Navigate to **Configuration > Channels** in the CCM and click the add button  next to the PGM and SA ports to put them into channels as required. These audio resources can be routed to **Channels, Groups, Roles** and **Logic** events (GPIOs).

**Note:** *These resource are unidirectional (simplex, not duplex).*

## 3.7 Setting the Management IP Address

By default your Arcadia Central Station works with DHCP IP addressing. However, you can set a static IP address for any of the station IP ports (with the exception of Dante audio that is defined by the Audinate Dante Controller).

The Management IP address can be set:

- From the Arcadia Central Station front panel menus
- From the Core Configuration Manager (CCM)

### 3.7.1 Setting the Management IP Address from the Front Panel Menus

1. Press the **MENU** button.
2. Using the far left rotary controller, navigate to **Networking**.
3. Select **(Management**.
4. Navigate to **DHCP** and select **DISABLED**. Push to select menu item.
5. A numerical touchscreen keypad appears in the screen.
6. Using the touchscreen, press **Clr** to clear the IP address field.
7. Enter the new IP address using the touchscreen.
8. Press **OK**.
9. Edit the subnet if required.
10. Press OK.
11. The Management IP address has been changed.

### 3.7.2 Setting the Management IP Address from the CCM

To access the CCM, see [Introduction to the CCM on page 30](#).

1. In the CCM, navigate to **Hardware > Resources**.
2. Click anywhere on the Arcadia Central Station panel under **Hosts**.
3. In the Network tab, click **Management**.
4. Select **Static**.
5. Enter the required IP address and press the [Enter] key.

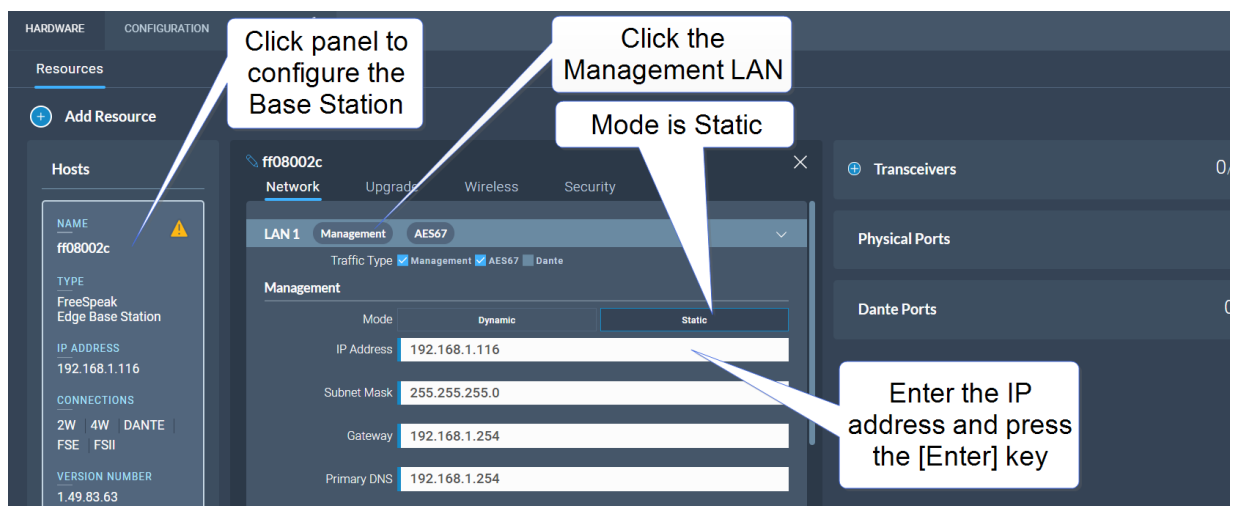

For more information, see: [Arcadia Central Station LAN Configuration Rules on page 61](#).

## 3.8 Saving and Restoring System Configuration

Clear-Com recommends that you make a backup of your system configuration using the Save option that is available in the CCM and the front panel menu system.

### 3.8.1 Saving System Configuration in the CCM

The **Save** and **Restore** options are available in the CCM top navigation bar.



When you click **Save**, all system configuration; channels, roles and network details are saved to a file (.cca) on your computer.

### 3.8.2 Saving System Setup in the Front Panel Menus

1. Insert a USB drive into the USB connector on the front of the Arcadia Central Station.
2. Press the **Menu** button.
3. Using the rotary controllers, navigate to **Administration > Settings > Save**.
4. Push the 4th rotary controller. System setting are saved to the USB drive. The progress of this Save is shown in the notification bar on the front panel.

### 3.8.3 Restoring System Configuration

Your system configuration can be restored to the Arcadia Central Station at any time using the **Restore** button in the CCM and also from the front panel menu system.

On restore, the saved configuration is reapplied to the Arcadia Central Station. The following aspects of the configuration are optionally restored:

- Network settings (IP addresses)
- Over The Air system ID.

You do not get these options when restoring by USB directly to the Arcadia Central Station. If you want to restore system settings taken from different Stations, you must use the CCM Restore option, as restoring directly from the Arcadia Central Station in this situation would restore network and OTA system ID and IP and could cause wireless ID conflicts.

## 3.9 Resetting to Default

Your Arcadia Central Station can be reset to default settings either from the front panel menus or from the Core Configuration Manager (CCM).

**Note:** *When you use a pin reset on front the front of the Arcadia Central Station the device reboots.*

### 3.9.1 Resetting to Default from the Arcadia Central Station Menu System

1. Press the **Menu** button on the front of the Arcadia Central Station.
2. Using the rotary controllers navigate to **Administration > Reset > Reset to Default > Reset Base**.
3. Press the 4th rotary controller.
4. The device will reset to factory defaults and reboot.  
Network settings are also reset, and the password is reset to default.

### 3.9.2 Resetting to Default from the CCM

1. In the CCM, navigate to **Status > Overview > Host Device**.
2. Select **Reset to Default**.
3. From the confirmation dialog box, click **Reset to Default**.
4. The device will reset to factory defaults and reboot.  
Network settings are not reset, and the password is also not reset.

# 4 Introduction to the CCM

---

This chapter describes the main pages of the Core Configuration Manager (CCM). It contains the following sections:

- 4.1 Accessing the CCM ..... 32
- 4.2 Changing the CCM Password ..... 33
- 4.3 Hardware Page Overview ..... 34
- 4.4 Configuration Page Overview ..... 35
- 4.5 Status Page ..... 39

---

The CCM is an easy-to-use browser-based software tool with intuitive menus that enable you to quickly set up, configure and edit your system. It provides an overview of all the system components and interfaces. It is password protected and suitable for use in poorly lit environments.

At-a-glance guide to using the Core Configuration Manager (CCM)

**HARDWARE**



This is where you will initially set up your system and resources

- Register transceivers and beltpacks
- Network setup
- Set 5 GHz channels on transceivers
- Interface port settings

**CONFIGURATION**

This is where you will configure the intercom aspect of your system: channels and audio keys



Add ports to channels



Roles: beltpacks, Station and other endpoints

**STATUS**



This section provides detailed status of system overview, information and performance



Click the pencil to edit a label



Click the cog to configure device settings

You can access the CCM using the following internet browsers:

- Chrome
- Safari
- Firefox
- Microsoft Edge

## 4.1 Accessing the CCM

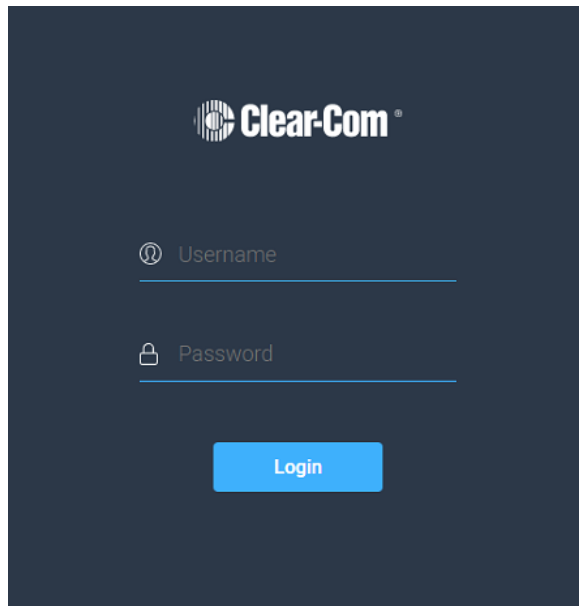
1. Make sure that the Arcadia Central Station is connected to a network using the LAN connector that is configured for management (Default LAN 1) on the rear panel of the device (see [Rear Panel Connectors and Indicators on page 22](#)).
2. Open a supported internet browser on a desktop that is connected to the same network as the Arcadia Central Station.
3. In the browser address field, enter the IP address of the Arcadia Central Station. You can find this from the front panel menus, see [Configuring from the Front Panel on page 114](#). The login screen appears:



If you enter an incorrect user name or password, an error message appears and you are prompted to re-enter your user credentials.

4. Enter the username and password, and then click **Login**.

The default values are:

- username: **admin**
- password: find the default password in the front panel menu system

**Note:** *The username and password are case sensitive.*



The CCM **Hardware** page opens.

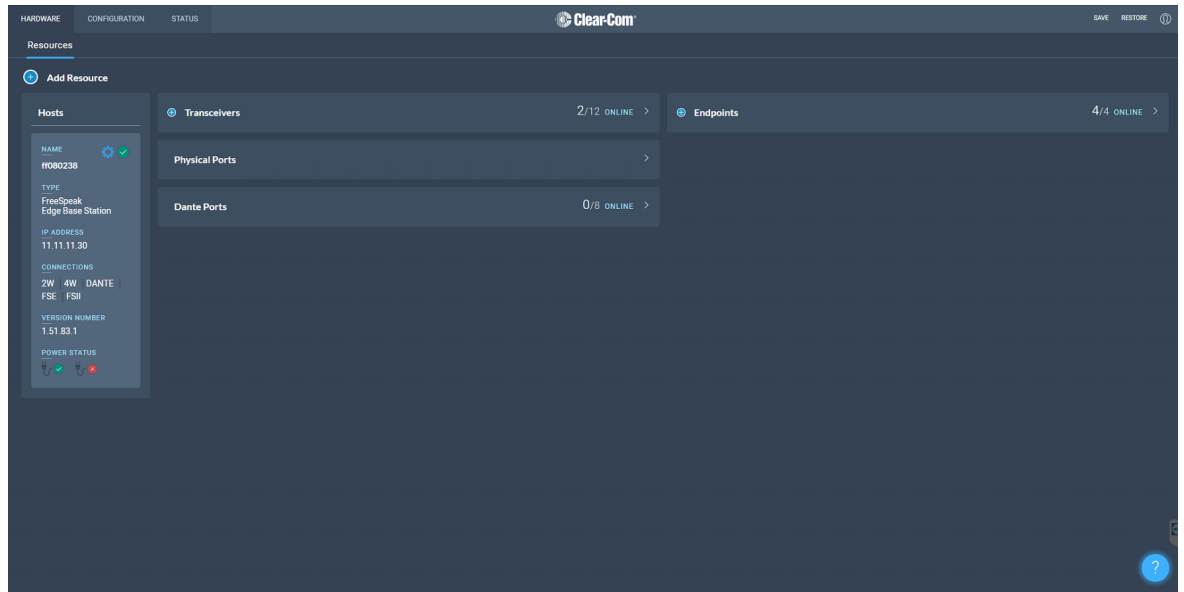

**Note:** On first opening the CCM, the **Hardware** page opens. On subsequent occasions, the **Status** page opens.

## 4.2 Changing the CCM Password

Change the password to one of your own choosing in the top right corner of the navigation bar.



**Note:** You can reset your password to the default at any time from the Arcadia Central Station front panel menus.

## 4.3 Hardware Page Overview

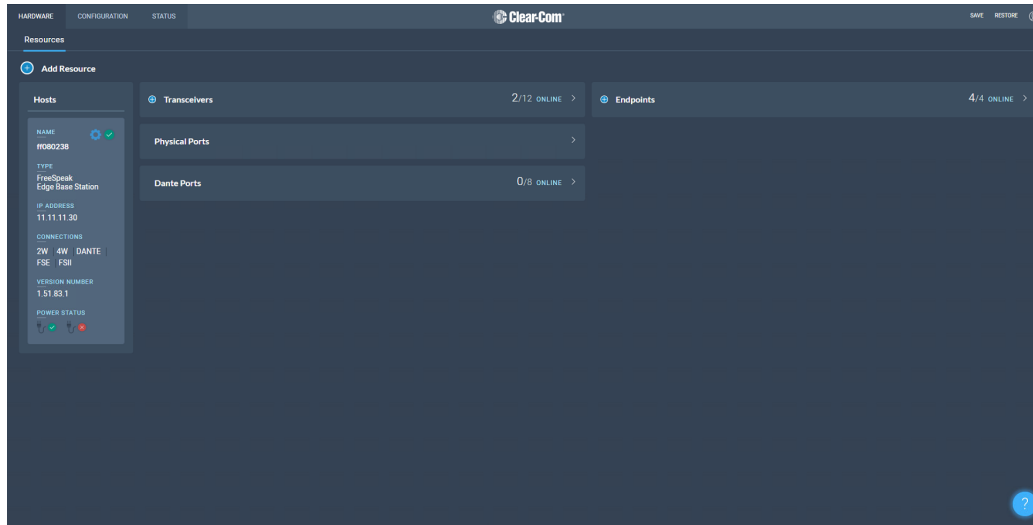

The Hardware page of the CCM is where you set up your system. It gives an overview of the hardware and ports that are present. From this page, you can use the **Add Resource** button to:

- View a list of both discovered and registered transceivers
- Add any discovered transceivers to the system
- Remove any registered transceivers from the system
- Register beltpacks to the system
- Create Dante ports (Arcadia Central Station only)

In the Hardware Resources page you can:

- Adjust settings on interface ports
- Configure network information (LAN ports and IP addresses) for the Station and transceivers
- Upgrade firmware
- Find and change administrative details, such as:
  - Administration PIN
  - OTA System ID
  - FreeSpeak Edge Wireless regions
  - Change FreeSpeak Edge 5 GHz channels
  - FreeSpeak II AA battery types and PINs

## 4.4 Configuration Page Overview

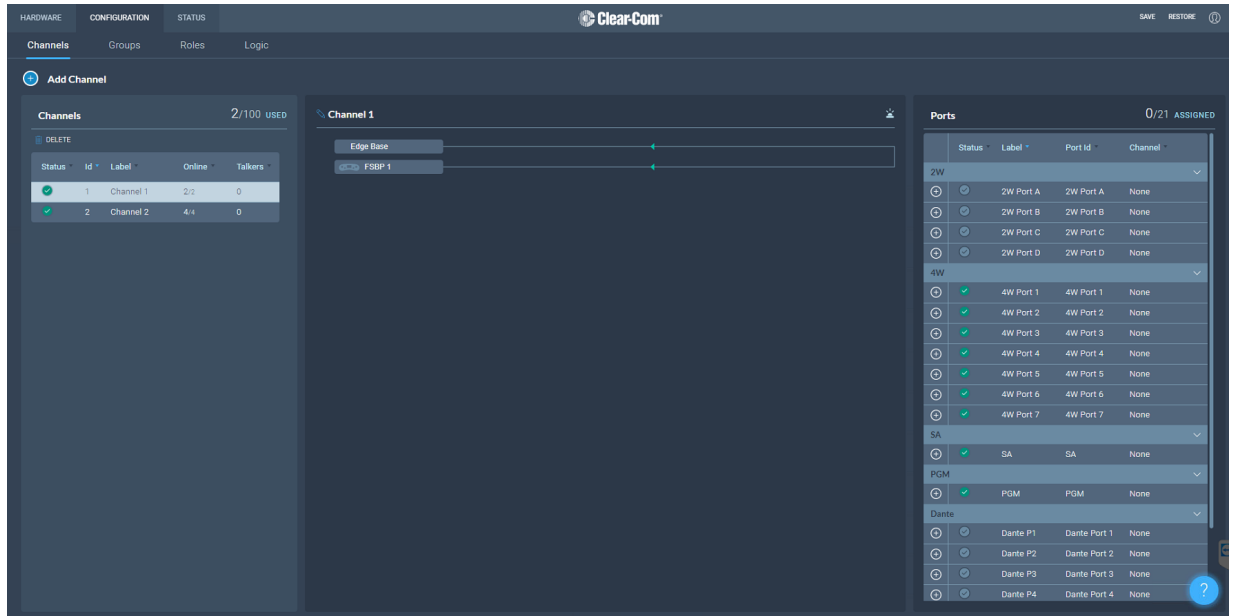

The **Configuration** page of the CCM is where you configure the intercom aspects of your system (add audio to channels and set up talk and call keys). It consists of four areas:

- Channels
- Roles
- Groups
- Logic (GPIOs)

The **Configuration** page enables you to:

- View existing channels and add new channels
- Add ports to channels
- View existing groups and add new groups
- View and edit roles
- View and edit General Purpose Inputs (GPIs) and General Purpose Outputs (GPOs)

## 4.4.1 Channels Page

The screenshot shows the 'Channels' page in the Clear-Com interface. The top navigation bar includes 'HARDWARE', 'CONFIGURATION', and 'STATUS'. The 'CONFIGURATION' tab is active, with sub-tabs for 'Channels', 'Groups', 'Roles', and 'Logic'. The 'Channels' sub-tab is selected.

The main content area is titled 'Add Channel'. On the left, there is a 'Channels' table with 2/100 used. The table has columns for Status, Id, Label, Online, and Talkers. Below the table is a 'Channel 1' configuration area with 'Edge Base' and 'FSBP 1' components. On the right, there is a 'Ports' table with 0/21 assigned ports. The ports are categorized by 2W, 4W, SA, PGM, and Dante.

Status	Id	Label	Online	Talkers
✓	1	Channel 1	2/2	0
✓	2	Channel 2	4/4	0

Status	Label	Port Id	Channel
2W	2W Port A	2W Port A	None
2W	2W Port B	2W Port B	None
2W	2W Port C	2W Port C	None
2W	2W Port D	2W Port D	None
4W	4W Port 1	4W Port 1	None
4W	4W Port 2	4W Port 2	None
4W	4W Port 3	4W Port 3	None
4W	4W Port 4	4W Port 4	None
4W	4W Port 5	4W Port 5	None
4W	4W Port 6	4W Port 6	None
4W	4W Port 7	4W Port 7	None
SA	SA	SA	None
PGM	PGM	PGM	None
Dante	Dante P1	Dante Port 1	None
Dante	Dante P2	Dante Port 2	None
Dante	Dante P3	Dante Port 3	None
Dante	Dante P4	Dante Port 4	None

The Channels page enables you to view channels and add ports to channels. Audio keys (beltpacks and other devices) are added to channels in the **Roles** page. The center panel on this screen shows the live state of audio routing.

## 4.4.2 Groups Page

The screenshot shows the 'Groups' page in the Clear-Com interface. The top navigation bar includes 'HARDWARE', 'CONFIGURATION', and 'STATUS'. The 'CONFIGURATION' tab is active, with sub-tabs for 'Channels', 'Groups', 'Roles', and 'Logic'. The 'Groups' sub-tab is selected.

The main content area is titled 'Add Group'. On the left, there is a 'Groups' table with 2/100 used. The table has columns for Status, Id, Label, Online, and Talkers. Below the table is a 'Group 1' configuration area with 'EDGE 1', 'EDGE 2', 'FSBP 1', and 'FSBP 2' components. On the right, there is a 'Ports' table with 0/20 assigned ports. The ports are categorized by 2W, 4W, SA, and Dante.

Status	Id	Label	Online	Talkers
✓	3	Group 1	4/4	0
✓	4	Group 2	0/0	0

Status	Label	Port Id	Group
2W	2W Port A	2W Port A	None
2W	2W Port B	2W Port B	None
2W	2W Port C	2W Port C	None
2W	2W Port D	2W Port D	None
4W	4W Port 1	4W Port 1	None
4W	4W Port 2	4W Port 2	None
4W	4W Port 3	4W Port 3	None
4W	4W Port 4	4W Port 4	None
4W	4W Port 5	4W Port 5	None
4W	4W Port 6	4W Port 6	None
4W	4W Port 7	4W Port 7	None
SA	SA	SA	None
Dante	Dante P1	Dante Port 1	None
Dante	Dante P2	Dante Port 2	None
Dante	Dante P3	Dante Port 3	None
Dante	Dante P4	Dante Port 4	None
Dante	Dante P5	Dante Port 5	None
Dante	Dante P6	Dante Port 6	None

The Groups Page allows you to view Groups and add ports to Groups. Roles are added to Groups in the **Roles** page.

### 4.4.3 Roles Page

The **Roles** page enables you to create roles for the devices in your intercom system.

Roles are made for:

- The Arcadia Central Station
- FreeSpeak II beltpacks
- FreeSpeak Edge beltpacks

A role can be made that can be used with either an FS II beltpack or an FS Edge beltpack (this role can only be used on one beltpack at any one time).

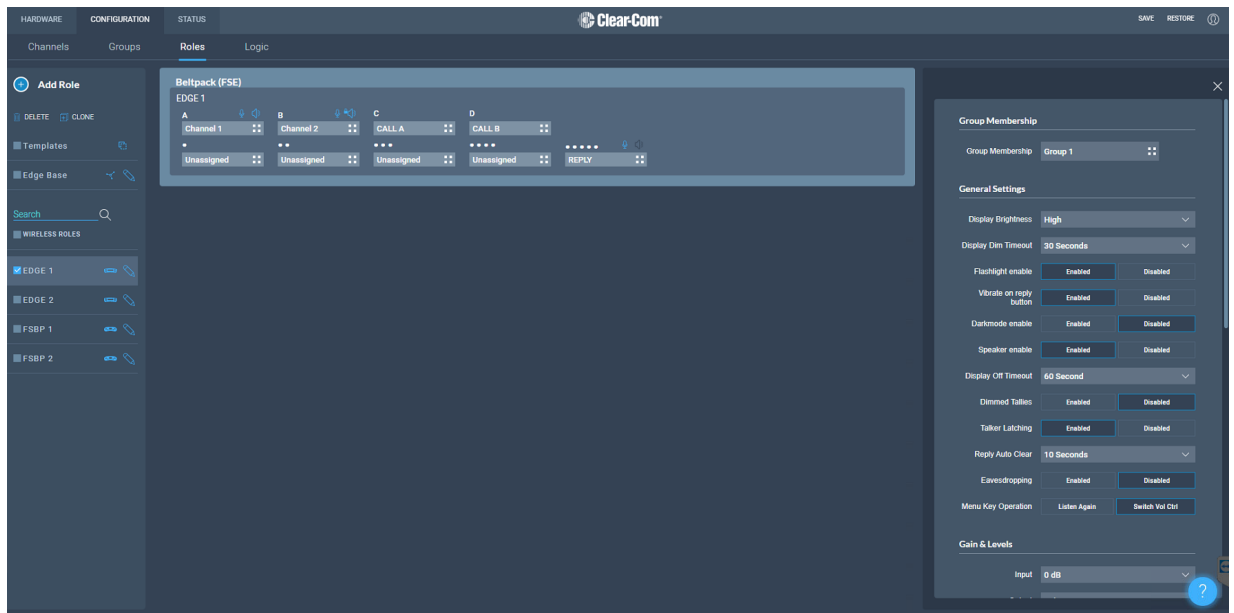

The **Roles** page of the CCM enables you to:

- View, edit, add and delete roles.

#### 4.4.4 Logic Page

The Arcadia Central Station offers six fully configurable GPIOs, increasing the range and possible uses of controls and relays.

- 2 x GPIs. These can be used, for example, to allow the station operator to open an audio route to a Channel using a foot switch, or to route a program feed to a Channel, Group or beltpack when an on-air light comes on.
  - Up to 10 different audio routes can be generated on each GPI.
- 4 x GPOs. The most common uses for output relays are to turn on an on-air light, connect to a radio, or send an input to an external audio console.
  - Up to 10 different actions can be generated on each GPO.
- You can also set up extended control sequences in the **Control Logic** section.

Relays (GPOs) and GPIs are configured in the **Configuration > Logic** page of the Core Configuration Manager (CCM) and can be viewed and tested on the **Status > Logic** page.

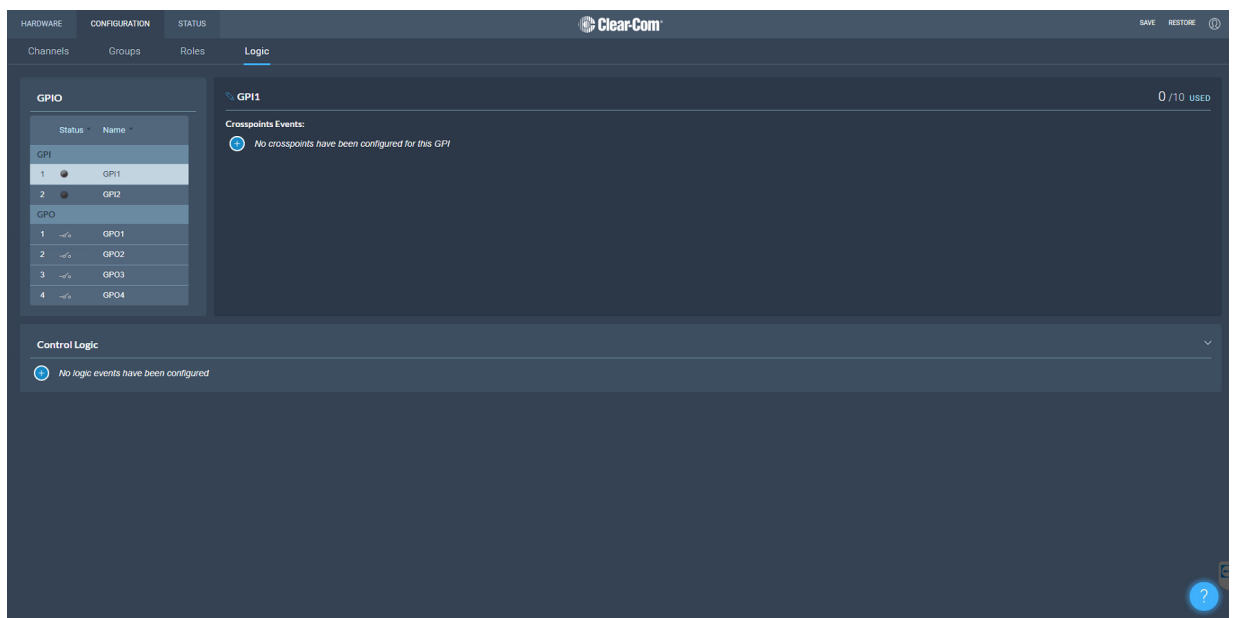

## 4.5 Status Page

The screenshot shows the Clear-Com CCM Status page. At the top, there are tabs for HARDWARE, CONFIGURATION, and STATUS. Below the tabs, there are filters for various resource types: HOST DEVICE (1/1), PHYSICAL PORTS (13/13), DANTE PORTS (55/55), TRANSCEIVERS (25/26), WIRELESS ENDPOINTS (22/32), ONLY EXCEPTIONS, and HIDE OFFLINE. A grid of status icons is visible, with one icon highlighted in yellow. Below the grid, there are tabs for 'Wireless' and 'Host Device'. The 'Host Device' tab is selected, showing details for a RAV4 device. The details are organized into several sections: Network (Management), General, Version, Dante, Network (AES67), PTP, Power, and Thermal. Each section contains specific configuration and status information for the device.

From the **Status** page of the CCM, you can view the status of all the resources that are connected to the Arcadia Central Station. These include:

- Transceivers
- Beltpacks
- Interface ports

Here you will see error and warning states.

**Note:** *Error states are used exclusively to indicate that audio via this resource is not working.*

You can quickly see if entities are:

- Offline
- Online
- Initializing

# 5 Example Applications

---

This chapter contains examples of typical applications. It contains the following sections:

- 5.1 Fast and Easy Setup: E1 ..... 41
- 5.2 Using E1 With Six Transceivers ..... 43
- 5.3 Using IP Transceivers with the Arcadia Central Station ..... 45
- 5.4 Split Frequency Setup (5, 2.4 and 1.9 GHz System) ..... 47

---



# 5.1 Fast and Easy Setup: E1

The FreeSpeak II E1 transceivers use an E1 connection (telecommunications standard) directly to the Arcadia Central Station. The Core Configuration Manager (CCM) is the easiest way to configure your system, but this setup can be configured with minimal use of the CCM if you work with the default role setup. Using the default setup, all devices have talk and forced listen keys to Channel 1 and Channel 2 and can engage call signals to those channels.

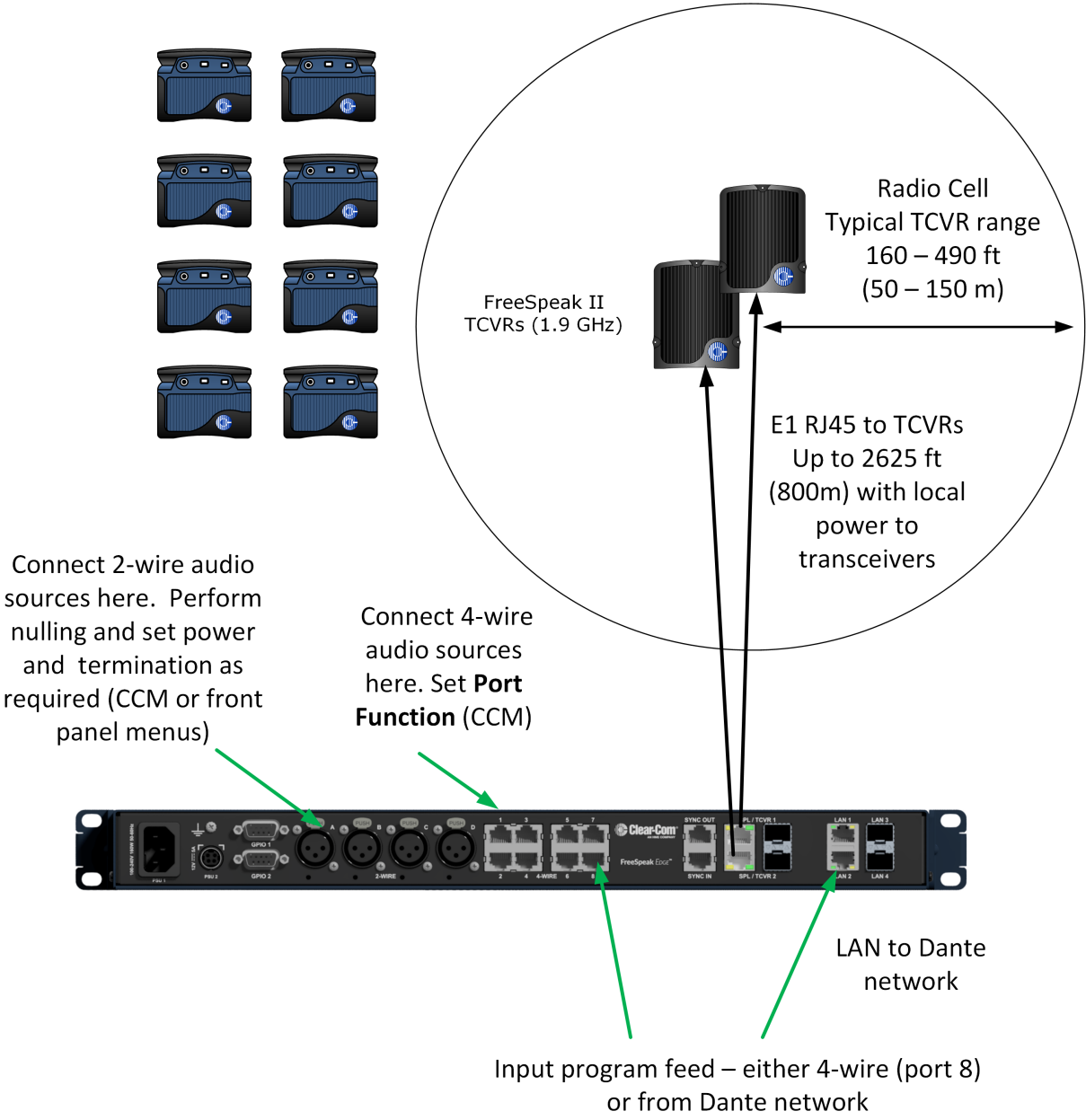

## 5.1.1 Outline of General Setup and Configuration

- For E1 setup, see [Connecting Transceivers Over E1 on page 50](#).
- To access the CCM, see: [Introduction to the CCM on page 30](#).
- To register beltpacks, see [Registering Beltpacks on page 80](#).
- To set Port Function, see [Port Function on page 67](#).
- To perform null and set power, see [Connecting 2-Wire Systems on page 63](#).
- To connect Program Feed, see [Stage Announce and Program Feed on page 26](#).

## 5.2 Using E1 With Six Transceivers

This setup includes two splitters, both connected via shielded Cat 5e cable using E1 connectivity. Four channels are configured in the CCM: Channel 1=ALL, Channel 2=Lighting, Channel 3=Sound, Channel 4=FoH. 16 roles are configured for the beltpacks.

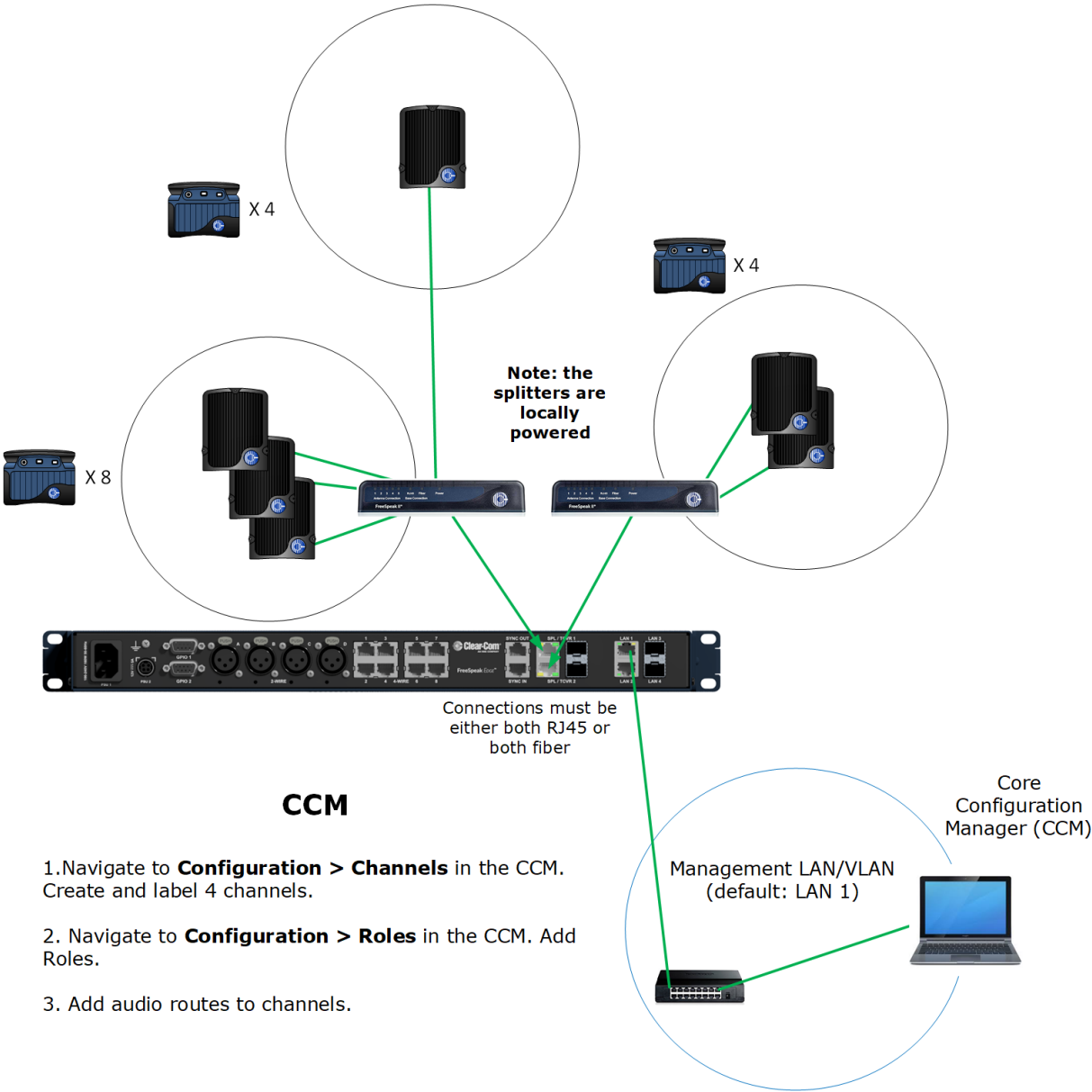

## 5.2.1 Outline of General Setup and Configuration

- For E1 setup, see [Connecting Transceivers Over E1 on page 50](#).
- To set the splitter DIP switches, see the FSII Splitter Quick Start Guide (FSII SPL-QSG) in the Clear-Com FreeSpeak II Knowledge Center on the Clear-Com website:  
[Clear-Com FreeSpeak II Knowledge Center](#)
- To access the CCM, see: [Introduction to the CCM on page 30](#).
- To register beltacks, see [Registering Beltacks on page 80](#).
- To set port settings for 2-wire sources, see [Connecting 2-Wire Systems on page 63](#).
- To set port settings for 4-wire sources, see [Connecting 4-Wire Systems on page 66](#).
- To connect program and stage announce, see:  
[Stage Announce and Program Feed on page 26](#).
- To configure channels, see [Managing Channels on page 84](#).
- To configure Roles, see [Creating and Editing Roles on page 94](#).

### 5.3 Using IP Transceivers with the Arcadia Central Station

This setup has a total of 6 FS Edge transceivers with 16 Beltpacks connected. The IP transceivers are connected via a network that is configured for AES67 traffic. These are configured using the CCM. There are four 2-wire partylines and a Dante network.

**Note:** The Dante network must be on a different VLAN or network from the IP transceivers.

**Note:** The AES67 network must be set up correctly for the IP transceivers in order to meet the needs of Clear-Com IP transceivers for high levels of PTP accuracy.

See the *AoIP Network Recommendations* guide, available from the [Clear-Com FSII Knowledge Center](#).

FS Edge 5 GHz  
beltpacks x 16

Register at the  
Base or in the  
CCM



**Note:** This setup assumes a dedicated network switch for the Edge Base, transceivers and CCM.

**Note:** You cannot configure the IP transceiver network (AES67) and Dante to the same network port.

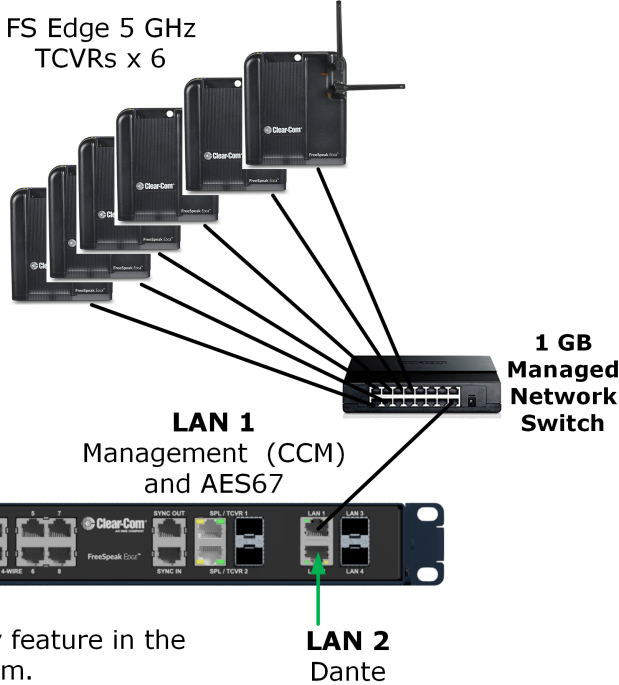

1. You will need to use the **Discovery** feature in the CCM to add transceivers to your system.
2. You will need to configure Dante feeds in the Audinate Dante Controller before these can be added to channels in the CCM.

Key

---

Cat5e/6a Shielded  
Ethernet cable  
23/24 AWG  
(max 100m)

### 5.3.1 Outline of General Setup and Configuration

- For network setup, see [Network Setup for IP Transceivers on page 56](#).
- To access the CCM, see: [Introduction to the CCM on page 30](#).
- To add IP transceivers to your system, see [Connecting Transceivers on page 48](#).
- For information on the connection process for IP transceivers, see the Quick Start Guides (QSGs) for FS Edge IP transceivers available from the [FreeSpeak Edge Knowledge Center](#).
- For information about connecting to 2-wire systems, see: [Connecting 2-Wire Systems on page 63](#).
- For information about connecting to Dante, see: [Connecting to Dante-Enabled Devices on page 70](#).
- For information about Channels, see [Managing Channels on page 84](#).
- For information about Roles, see [Creating and Editing Roles on page 94](#).

## 5.4 Split Frequency Setup (5, 2.4 and 1.9 GHz System)

This setup has:

- E1 FS II transceivers (1.9) with 5 beltpacks
- FS Edge IP transceivers (5) with 6 beltpacks
- FS II IP transceivers (2.4) with 5 beltpacks.

The E1 Transceivers will automatically connect to the Arcadia Central Station once powered, but the Edge and IP transceivers require additional configuration in the CCM and must be connected to a network that is configured for AES67 traffic.

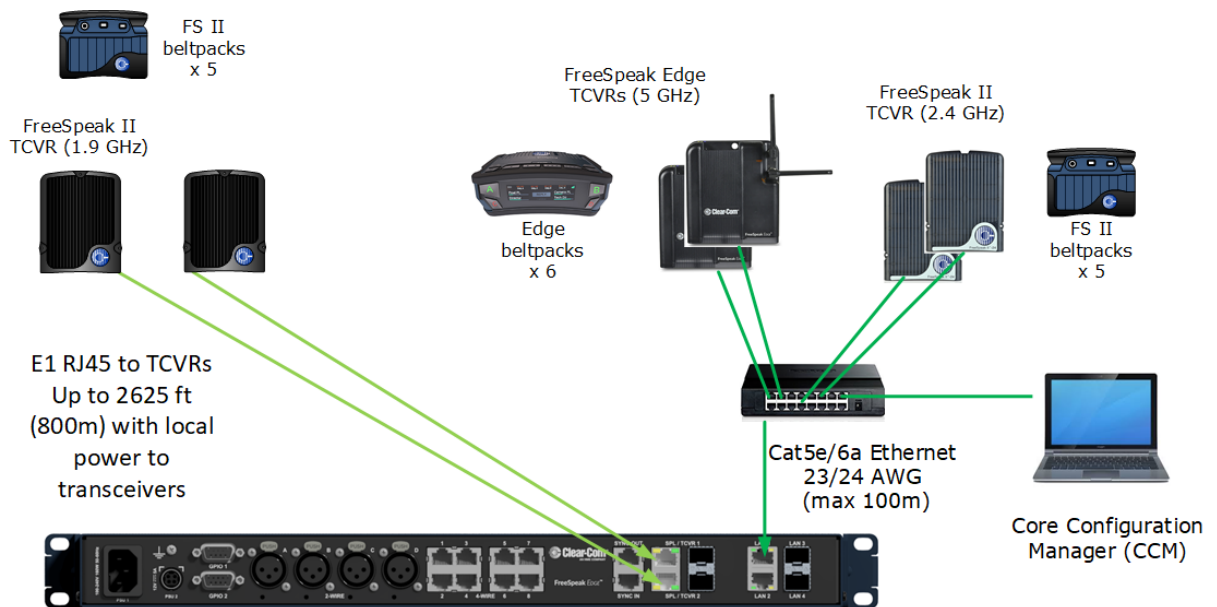

### CCM Configuration

2 x Channels: Cameras, Lighting

16 x Roles: Director, Stage Manager, Runners, Maintenance, Lighting, Sound

**Note:** you can create roles that can be used by FS Edge and/or FS II beltpacks (the role can only be used by 1 beltpack at any given time).

# 6 Connecting Transceivers

---

This chapter describes how to connect to E1 and IP transceivers. It contains the following sections:

6.1 Overview of Transceivers .....	49
6.2 Connecting Transceivers Over E1 .....	50
6.3 Connecting Transceivers Over IP .....	54

---



# 6.1 Overview of Transceivers

FreeSpeak II (2.4)



FreeSpeak II (1.9)



E1 connectivity

FreeSpeak II (1.9) IP transceiver



FreeSpeak Edge (5) IP transceiver



IP connectivity

## 6.2 Connecting Transceivers Over E1

E1 is a telecommunications standard whereby data and power are sent over Cat 5/6 or Fiber cable (data only). E1 connections must have dedicated cabling as it is not possible to use network switches with this technology.

FreeSpeak II systems (1.9 and 2.4 GHz) can be connected to the Arcadia Central Station using E1 connectivity.

**Note:** *You must not connect E1 1.9 GHz and IP 1.9 GHz transceivers at the same time.*

Transceivers can be connected directly to the Arcadia Central Station (up to two transceivers) or connected using FreeSpeak II splitters (up to 2 splitters, each hosting up to 5 transceivers so up to 10 transceivers in total).

Transceivers/splitters are connected to the Arcadia Central Station using connectors G and H. See [Rear Panel Connectors and Indicators on page 22](#).

**Note:** *Transceivers and splitters can be connected using Fiber or copper cable. If you use Fiber, the devices MUST have local power and you MUST configure the ports to fiber in the CCM (default = RJ45). Navigate to: **CCM > Host > Wireless > Wireless Transceivers**.*

Example connection with a splitter



**Note:** *The splitter connections are switched between RJ45 and Fiber routing using DIP switches inside the splitter.*

For more examples of connection options and how to set the DIP switches, see the FreeSpeak II Splitter Quick Start Guide available from the [FreeSpeak II Knowledge Center](#).

## 6.2.1 Cable Distances - E1 Connections

Arcadia Central Station to TCVR/splitter	
TCVR directly connected to and powered by the Arcadia Central Station	<ul style="list-style-type: none"> <li>• 328 ft (100 m) using shielded 24 AWG Cat 5/6e cable</li> <li>• 164 ft (50 m) using shielded 26 AWG Cat 5/6e cable</li> </ul>
TCVR directly connected to the Arcadia Central Station with local/direct power at TCVR	<ul style="list-style-type: none"> <li>• 2625 ft (800 m) using shielded 24 AWG Cat 5/6e cable</li> <li>• 1312 ft (400 m) using shielded 26 AWG Cat 5/6e cable</li> </ul>
Arcadia Central Station to splitter (splitter is powered)	<ul style="list-style-type: none"> <li>• 2625 ft (800 m) using shielded 24 AWG Cat 5/6e cable</li> <li>• 1312 ft (400 m) using shielded 26 AWG Cat 5/6e cable</li> </ul>

Splitter to TCVRs	
TCVRs powered by splitter	<ul style="list-style-type: none"> <li>• 328 ft (100 m) using shielded 24 AWG Cat 5/6e cable</li> <li>• 164 ft (50 m) using shielded 26 AWG Cat 5/6e cable</li> </ul>
TCVRs have local/direct power	<ul style="list-style-type: none"> <li>• 2625 ft (800 m) using shielded 24 AWG Cat 5/6e cable</li> <li>• 1312 ft (400 m) using shielded 26 AWG Cat 5/6e cable</li> </ul>

**Note:** *Fiber connections: Connection distances will depend on existing cable infrastructure.*

## 6.2.2 Using a Transceiver With a Fiber Connection

To connect a Arcadia Central Station to a splitter (FSII-SPL) using Fiber, you must install Fiber modules to the Arcadia Central Station and the splitter.

- Modules are available for single mode Fiber cable (HLI-SMFO) and multi-mode Fiber cable (HLI-MMFO).
- Modules, which must be ordered from Clear-Com are supplied as a pair, one for the Arcadia Central Station and one for the splitter.
- Modules can be hot patched. There is no need to power off devices.
- To install the modules, simply remove the dust cap from the connector port and slide the module into the connector.

**Note:** *When using a Fiber connection, all devices must have local power supplied.*

## 6.2.3 E1 Transceiver/Splitter Port Connection Type (RJ45 or Fiber)

Transceivers/splitters can be connected to the Arcadia Central Station using either RJ45 cable or fiber cable.

The connection type for the ports is determined by a software setting in the Core Configuration Manager (CCM). Default setting is **RJ45**.

The CCM determines the connection type for both connectors; you must chose either RJ45 or Fiber. It is not possible to mix these connection types on the Arcadia Central Station.

### Setting FSII Transceiver/Splitter Connection Type

1. In the CCM, navigate to **Hardware > Hosts > Wireless**.
2. Select **FreeSpeak II > Transceiver Port** type as required.

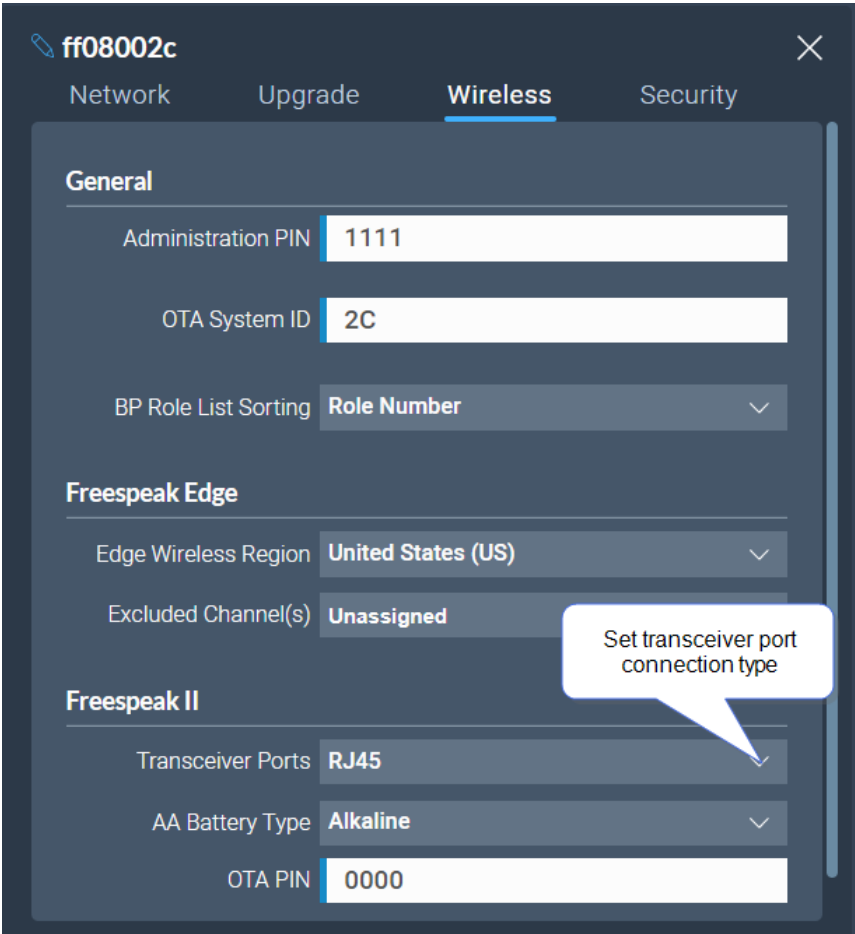

## 6.2.4 Setting Cable Length Offset (E1)

Cable length offset is used to prevent the DECT or radio signals between transceivers getting out of synchronization. If transceivers are not synchronized, beltpack handover will not happen effectively. This is particularly important if you have overlapping transceiver coverage zones (RF cells) or the beltpacks need to move between coverage zones.

Cable length offset or transceiver sync compensation needs to be set when:

- The difference in total cable length between transceivers is  $\geq 1640\text{ft} / 500\text{m}$  (this includes both fiber and copper cable runs).

### Example

TCVR #1: total cable length = 328ft / 100m

TCVR #2: total cable length = 2788ft / 850m

The difference in cable length between transceivers = 2460ft / 750m. Therefore, in this case you must set transceiver cable length on both transceivers. This allows any latency to be calculated and offset by the system.

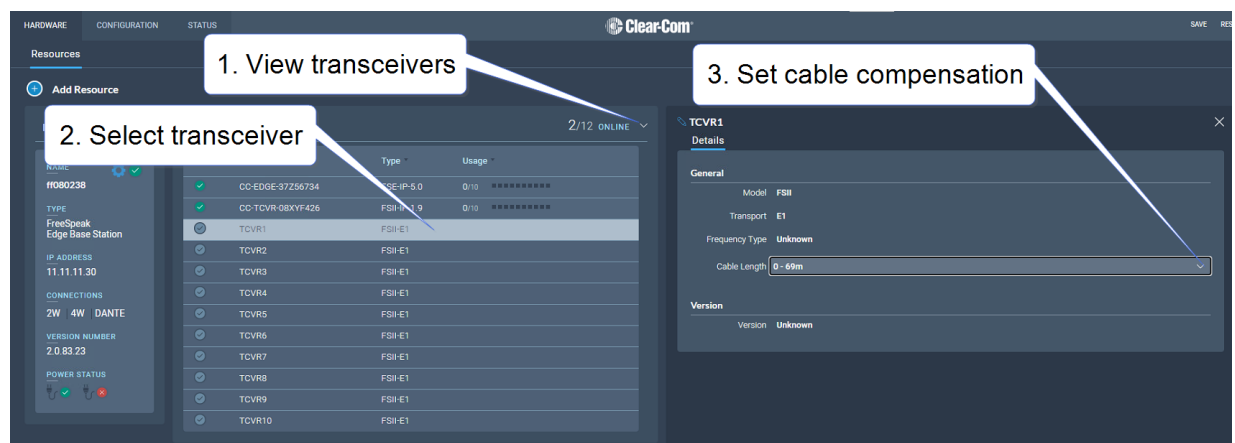

In the configuration tool, navigate to: **Resources > Transceivers > Details > General > Cable Length**

## 6.3 Connecting Transceivers Over IP

When connecting IP transceivers, connect them to the LAN connector that is configured for AES67 on the rear of the Arcadia Central Station using Ethernet cable.

See [Network Setup for IP Transceivers on page 56](#).

Once your transceivers are set up on the network you will add them to your system using the CCM or the Front Panel.

See [Adding IP Transceivers \(FS Edge, FS II 1.9\) on page 79](#).

# 7

## Network Setup

---

This chapter describes how to set up and configure your network for Arcadia Central Station IP transceivers. It contains the following sections:

7.1 Network Setup for IP Transceivers .....	56
7.2 Arcadia Central Station LAN Configuration Rules .....	61

---

# 7.1 Network Setup for IP Transceivers

The Arcadia Central Station has four IP addresses. IP traffic is spread over these addresses. See LAN ports 1 - 4 ( I and J). See [Rear Panel Connectors and Indicators on page 22](#).

The LAN ports are fully user configurable but you can work with the following default settings:

- LAN 1: Management and AES67 (AoIP) audio traffic are combined on this connector
- LAN 2: Not configured
- LAN 3: Not configured (SFP)
- LAN 4: Not configured (SFP)

## 7.1.1 Connection to IP Transceivers, Example 1

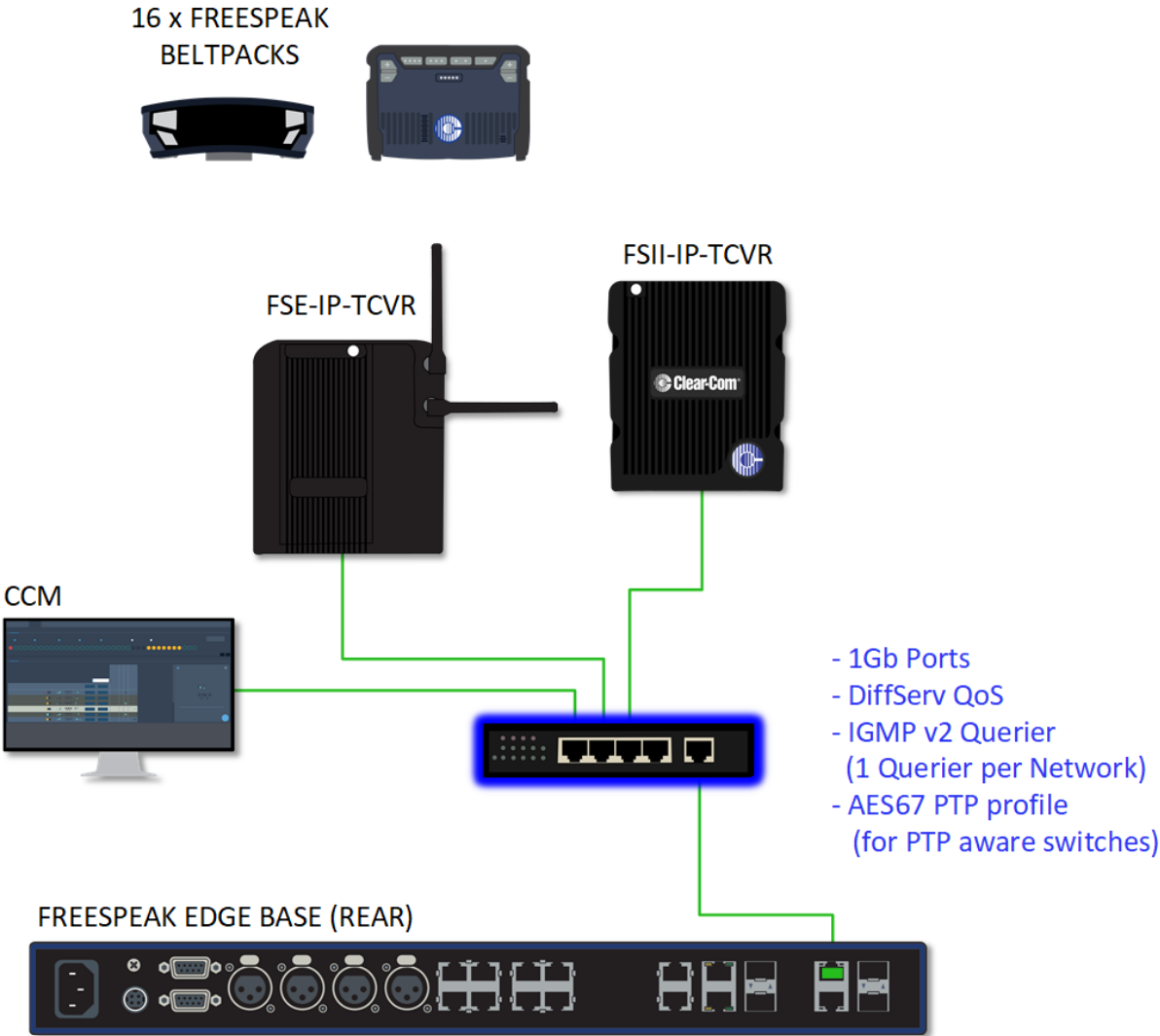



### 7.1.2 Connection to IP Transceivers and Dante, Example 2

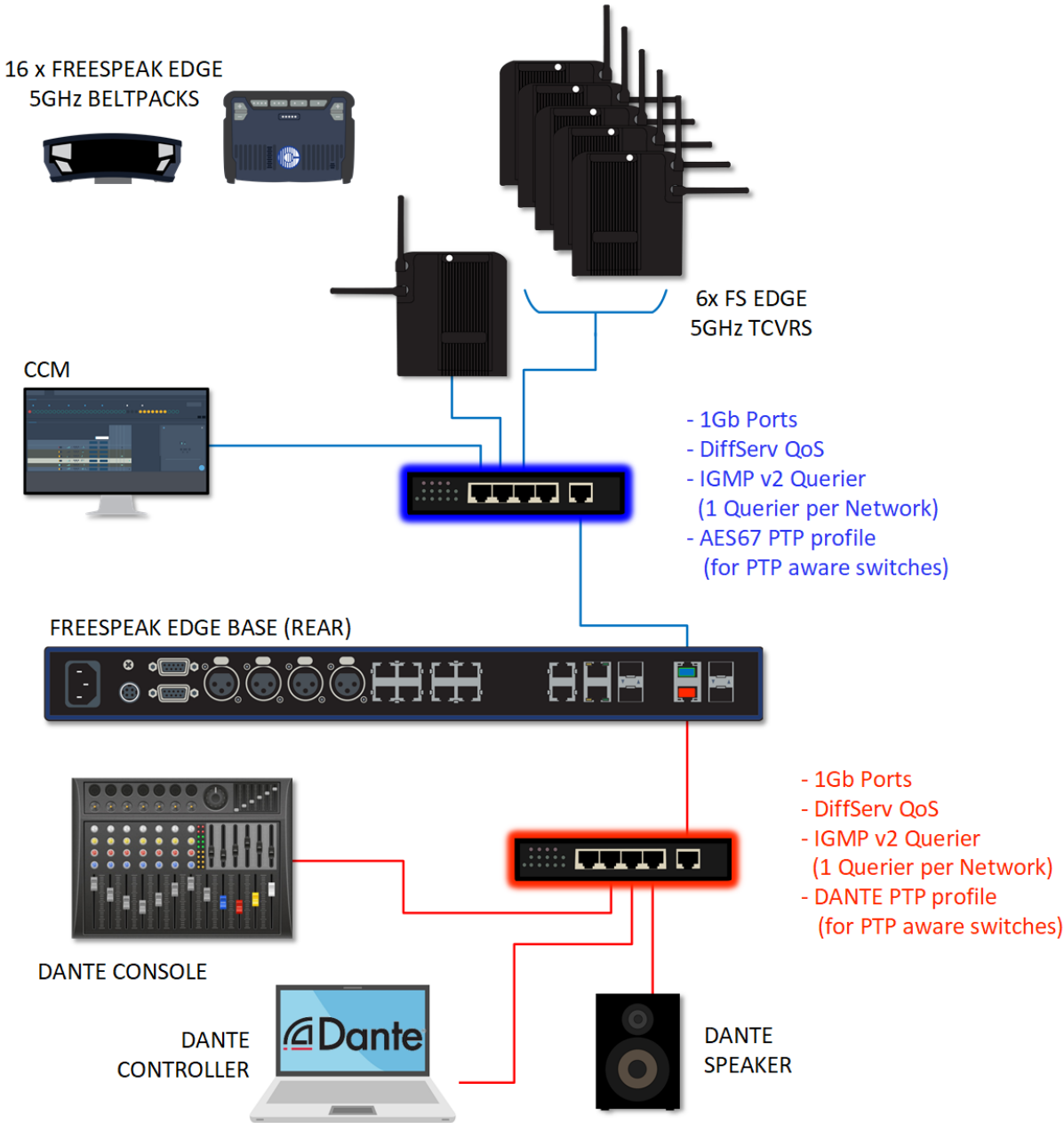

### 7.1.3 Connection to IP Transceivers and Dante, Example 3

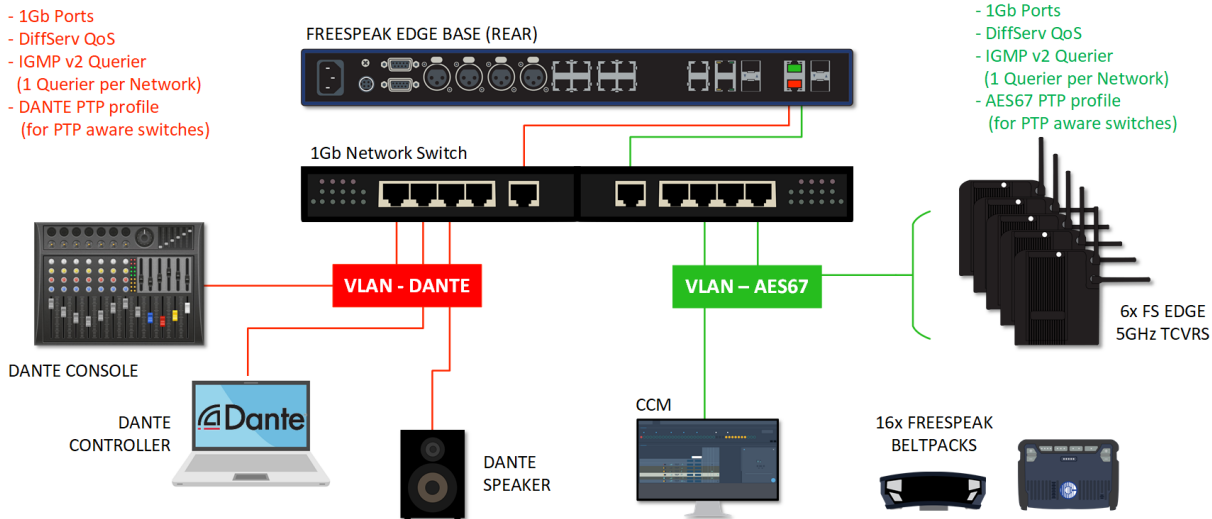

### 7.1.4 Connection to IP Transceivers, Example 4

If you are connecting to a network set up where there is lots of traffic, either management or AES67, Clear-Com recommends that you split AES67 traffic into its own segment.

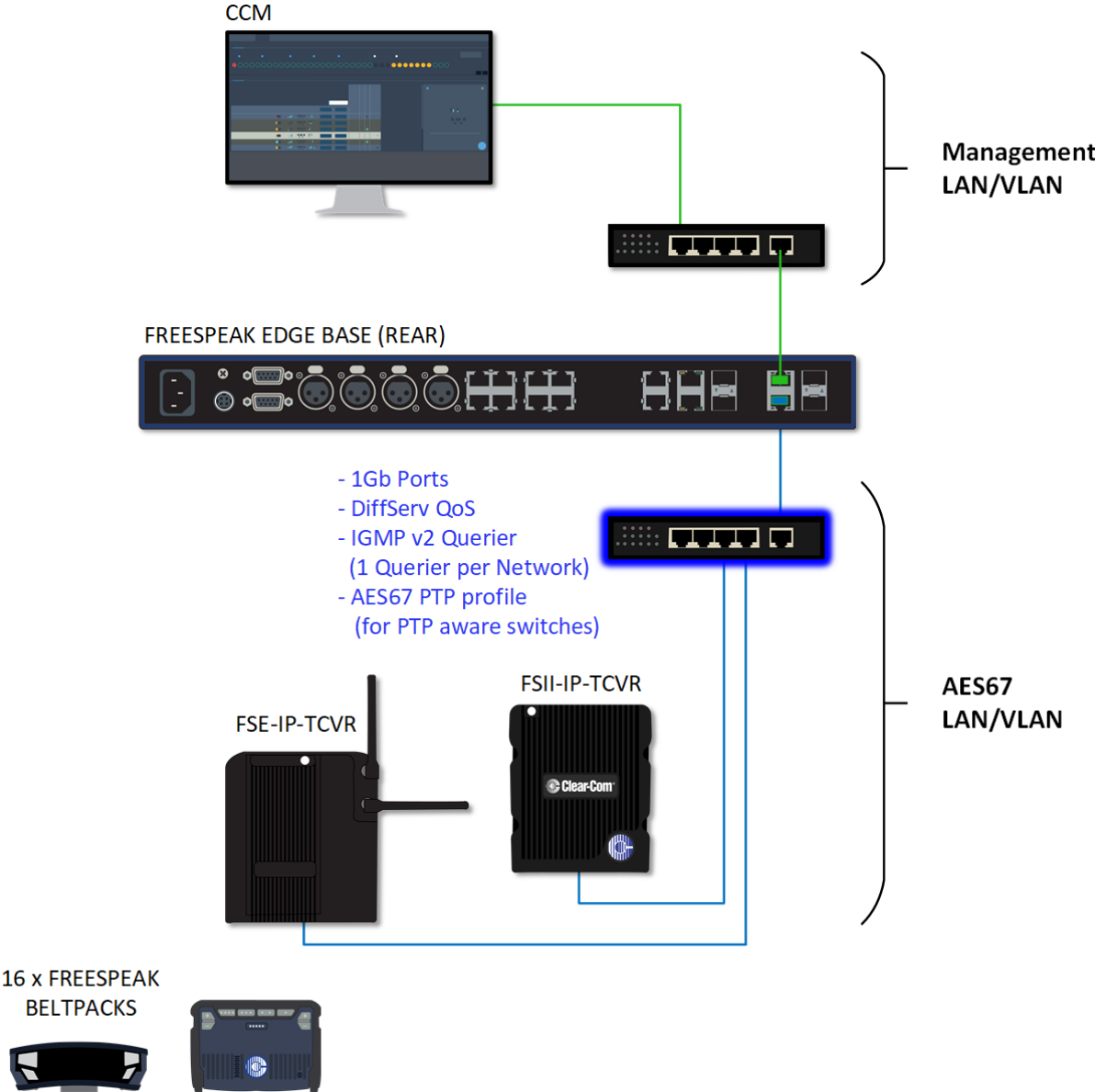

## 7.1.5 Setup Rules

- The default setup (management and AES67 audio on the same connector) is intended for use with a dedicated network switch for the Arcadia Central Station and its transceivers (see example network setup, example 1).
- If you do not have a network switch that is dedicated to the Station and transceivers, Clear-Com recommends that you split AES67 traffic onto a separate LAN (see example network setup, example 4). This is in order to accommodate the IP transceivers' need for high clocking accuracy. Too much traffic on your network will degrade the performance of your IP transceivers.
- For the AoIP network, try to keep the number of layer 2 hops between PTP leader and follower as low as possible (no more than 3). If more are required, consider using a Boundary Clock or a Transparent Clock.
- For more information on achieving a well-regulated PTP network and recommendations for suitable switches, see *Clear-Com AoIP Network Recommendations* available from the [FreeSpeak II Knowledge Center](#).
- Use DHCP (the default setting) for fast and easy setup of the devices. If the device does not encounter a DHCP server on the network it will automatically allocate an address in the link-local range (169.254.xx.xx).
- IP addresses can be configured statically under **Hardware > Resources > Network** in the CCM.
- For information on the 5 GHz transceiver (status and connection indicators) see the *Edge Transceiver Quick Start Guide* available from the [FreeSpeak Edge Knowledge Center](#).
- Connection status indicators on the FreeSpeak II IP transceiver are the same as the Edge transceiver (no channel scan).
- For PoE to the transceivers you will need a PoE enabled network switch.

## 7.2 Arcadia Central Station LAN Configuration Rules

**Note:** *Do not plug any two LAN ports into the same LAN or VLAN. This can create a network loop affecting IP stability.*

**Note:** *Configuring/changing the AES67 IP address will cause the Arcadia Central Station to reboot.*

### AES67 Rules

- AES67 should not be on the same subnet as Management unless they are on the same LAN port (rear port)
- AES67 cannot be on the same LAN port as DANTE primary or secondary

### IP Rules

- The IP addresses cannot be in the reserved range: 10.0.0.0-10.0.0.7
- The IP addresses cannot be in the LQ tunnel range 172.23.xxx.xxx
- The IP addresses cannot be in the localhost range 127.xxx.xxx.xxx
- The IP addresses cannot be in the multicast range 224.xxx.xxx.xxx-239.xxx.xxx.xxx

### Static IP Rules

- The static IP addresses cannot be in link local range: 169.254.xxx.xxx

### Dante Rules

- Dante primary and secondary cannot be on the same LAN port (rear connector)

### Management Rules

- You cannot disable Management

# 8 Connecting to other systems

---

This chapter describes how to connect your Arcadia Central Station with other intercom systems. It contains the following sections:

- 8.1 Connecting 2-Wire Systems ..... 63
- 8.2 Connecting 4-Wire Systems ..... 66
- 8.3 Connecting to Dante-Enabled Devices ..... 70

---

## 8.1 Connecting 2-Wire Systems

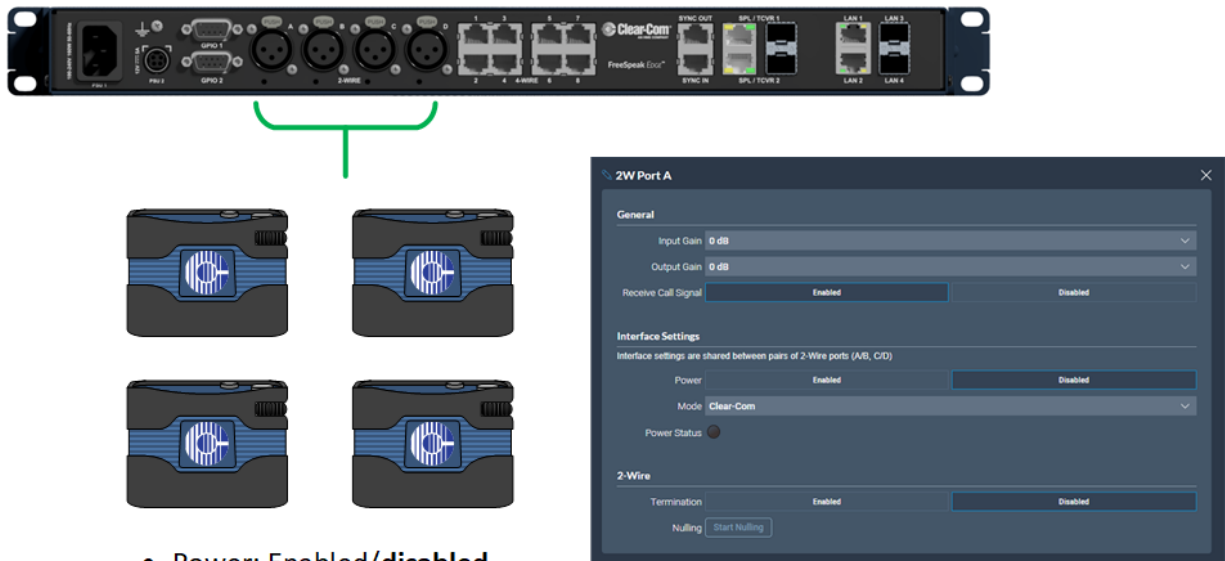

- Power: Enabled/**disabled**
- Mode: **Clear-Com**/RTS
- Termination: Enabled/**disabled**
- Nulling: Start Nulling

When connecting 2-wire equipment the following applies:

- Every time equipment is changed on a 2-wire interface (port) you should perform nulling. You must null every time you add wired resources to your system.
  - No one should listen during the nulling process.
  - It is good practice to press the remote mic kill (RMK) button on all channels before nulling.
- Beltpacks can be powered by the Arcadia Central Station via the partyline. Quantity of beltpacks and length of cable are variables, dependent on the type of devices and existing cabling. To calculate what will work best in your circumstances, see the [Encore Partyline Power Calculator](#), available from the Clear-Com website.
- Enable/disable the partyline power. Default setting: **Disabled**.

These functions can be set either in the 2-wire port settings page of the Core Configuration Manager (CCM) or from the front panel screens on the Arcadia Central Station.

- Enable/disable Line termination. The line should only be terminated once on interconnected devices, do not terminate on more than one piece of equipment. Default setting: **Disabled**.

Line termination is set in the CCM (not the front panel menu system). To do this, in the CCM navigate to: **Hardware > Resources > Physical Ports**. See below.

To configure 2-wire port settings in the CCM navigate to: **Hardware > Resources > Physical Ports > (select port)** :

**2W Port A**

Output Gain **0 dB**

Receive Call Signal **Enabled** **Disabled**

**Interface Settings**

Interface settings are shared between pairs of 2-Wire ports (A/B, C/D)

Power **Enabled** **Disabled**

Mode **Clear-Com**

Power Status

**2-Wire**

Termination **Enabled** **Disabled**

Nulling **Start Nulling**



## 8.1.1 Using Stations to Interconnect Equipment

When connecting Clear-Com Stations to other Clear-Com equipment and third-party systems (2-wire) use the following guidelines.

Device Type	Supports call signalling?
HelixNet HLI-2W2*	Yes
Encore MS-702/4	Yes
Encore RS Beltpack RS-701 / 702 / 703	Yes
RTS 2-wire equipment	Yes, but does not pass call signalling to 4-wire audio routes.
FreeSpeak/FreeSpeak II Base II*	Yes**
2-way radio	Yes, via a TW-47 interface

\*Where there is a choice between a 2-wire and a 4-wire connection, 4-wire provides the best audio quality and is preferred.

\*\* On a FreeSpeak II Base Station only ports 3 and 4 support call signalling.

## 8.2 Connecting 4-Wire Systems

When connecting to 4-wire equipment the following applies:

- To minimize noise and meet regulatory requirements, use screened (shielded) cable when connecting 4-wire ports.
- Pinout configuration (Port Function) can be set on all the Arcadia Central Station 4-wire interfaces. This is a software switch that switches the configuration of the pins on the RJ45 connectors according to the device you are connecting to. Default setting: **4-wire-X**.

### 8.2.1 Example Connections

Edge Base Station connected to an Eclipse Matrix

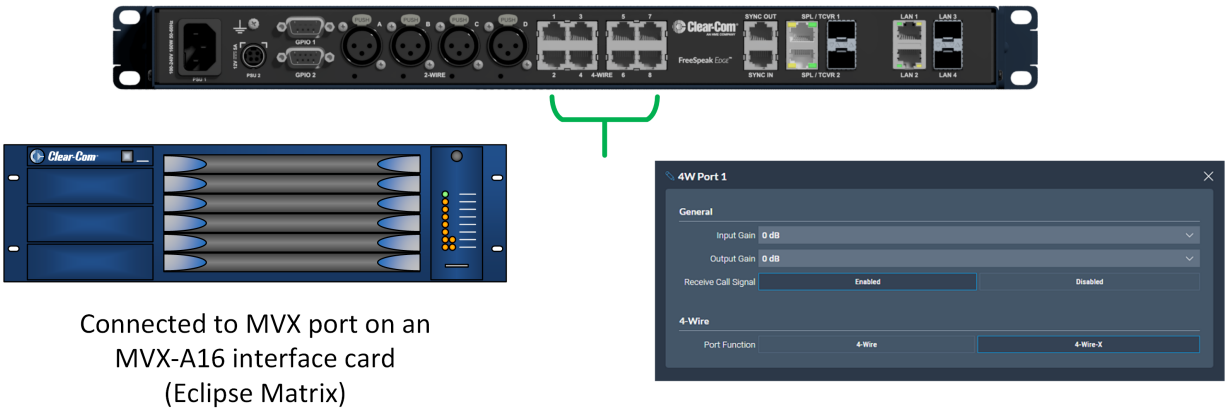

- Call signal: **Enabled**
- Port Function type set to : **4-wire-X**

### Edge Base Station connected via Cat5 to a HelixNet Base Station



HelixNet 4-wire module (HLI-4W2)

- Call signal: **Enabled**
- Port Function type is set to: **4-wire**

### 8.2.2 Port Function

Check this function whenever you are connecting 4-wire devices (not GPIO DB-9M connectors) to your Arcadia Central Station. Default = **4-wire-X**.

#### About Port Function

Clear-Com products are designed so central audio routing devices (base stations and matrices) can connect directly to other Arcadia Central Stations using a straight-through CAT 5/6 cable. The pin assignments (inputs and outputs) on these devices are complementary. Previously, a crossover cable was necessary when connecting bases to other bases (RJ45 connector). It is no longer necessary to use a crossover cable as there is now a **Port Function** toggle which changes pinouts as required. To set this function navigate in the CCM to **Hardware > Resources > Physical Ports** and select the required 4-wire port.

#### Port Function Pinouts

Pin No	4-wire	4-wire-X (default)
1	Data in +	Data out +
2	Data in -	Data out -
3	Audio in +	Audio out +
4	Audio out +	Audio in +
5	Audio out -	Audio in -
6	Audio in -	Audio out -
7	Data out +	Data in +
8	Data out -	Data in -

## Setting Port Function (Pin Polarity) on a 4-Wire Connection

1. Connect the devices using 1:1 Cat5/6/6e cable.
2. In the CCM, navigate to **Hardware > Resources > Physical Ports**.
3. Select the 4-wire port.
4. Select **Port Function**.

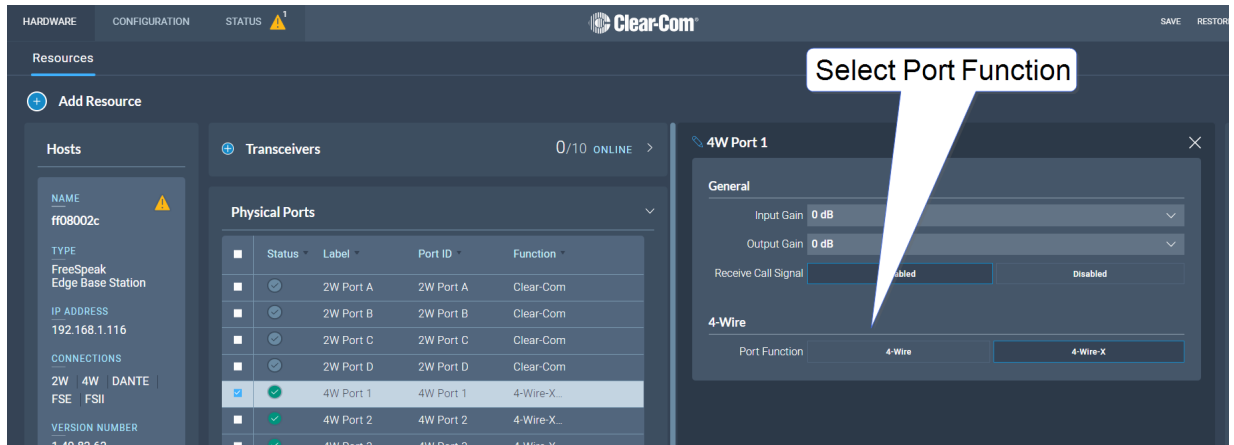

### 8.2.3 Using Stations to Interconnect Equipment

When connecting Clear-Com Stations to other Clear-Com equipment and other third-party systems (4-wire) use the following guidelines:

Device Type	Port Function	Supports call signalling?
HelixNet HLI-4W2	<b>4-wire</b>	Yes
MVX-A16 (Eclipse Matrix)	<b>4-wire-X</b>	Yes (Identified as a CCI-22 in the software)
Other matrices (third party)	Depends on third-party pinout	No
HME DX210/DX410	<b>4-wire</b>	Yes
FreeSpeak/FreeSpeak II Base II	<b>4-wire</b>	Yes**
FreeSpeak Edge Base Arcadia Central Station	When connecting two Stations with a straight cable, the <b>Port Function</b> settings must be as follows:  Station 1: <b>4-wire</b>  Station 2: <b>4-wire-X</b>	Yes
2-way radio : 4-wire device with relay activation *	Depends on third-party pinout	Yes (call signal can fire relay)

\* Connect to a DB9 on the Station rear.

\*\* On a FreeSpeak II Base Station only ports 3 and 4 support call signalling.

## 8.3 Connecting to Dante-Enabled Devices

To configure Dante connections you must be familiar with the Audinate Dante Controller, available from the Audinate website.

Before configuring the connection in the Dante Controller, you must determine which of the 4 RJ45 LAN connectors on the Arcadia Central Station you wish to use for Dante network traffic. See [Rear Panel Connectors and Indicators on page 22](#).

**Note:** *The PC running the Audinate Dante Controller must also be connected to the Dante network.*

**Note:** *The Dante connection on the Station supports both Dante and Dante (AES67).*

Determining which LAN connector you wish to use for Dante must be done in the CCM.

Navigate to **Hardware > Resources** and click on the host panel to see the host device settings. Under the **Network** tab, select the port for Dante. This port will default to a DHCP setting. If you wish to configure a static IP address you must do this in the Dante controller.

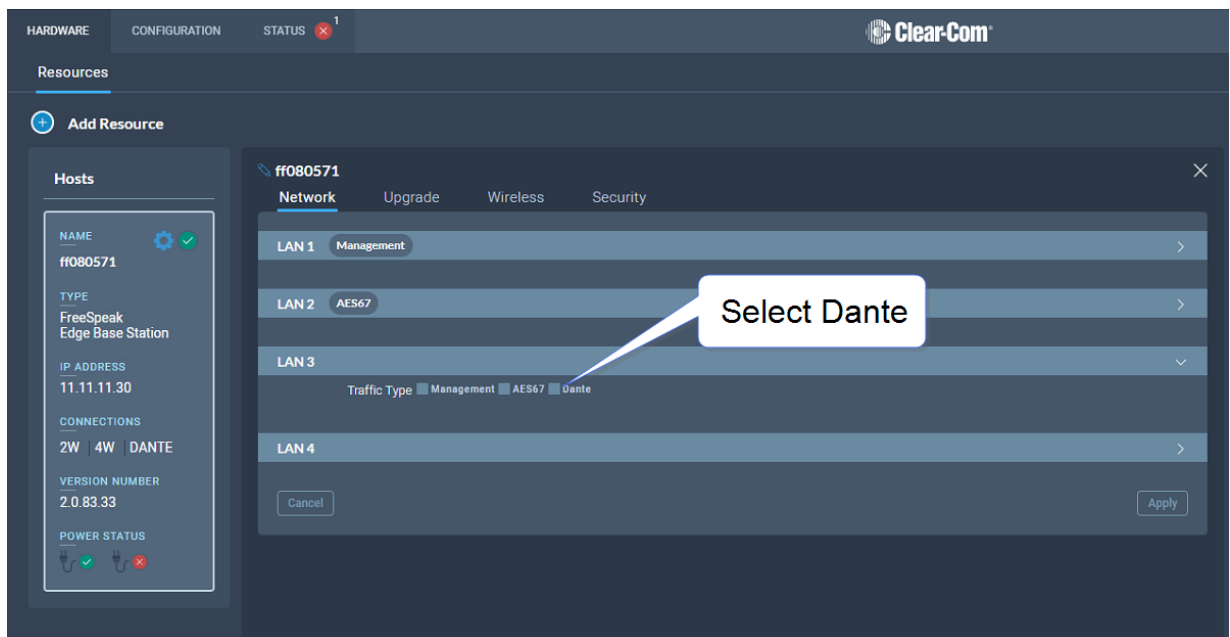

**Note:** *LAN 3 and 4 are for use with an SFP module (either fiber or RJ45).*

LAN connectors can be configured in any way you wish, but the CCM enforces that you **MUST NOT** configure IP transceivers (AES67) and Dante traffic on the same network. This is because AES67 network traffic has higher timing requirements than Dante network traffic, due to the need for IP transceivers to achieve DECT synchronization.

When configuring Dante connections, the Dante subsystem IP configuration is determined by the Dante Controller.

1. In the CCM, navigate to **Hardware > Resources > Host > Network** and configure Dante on the LAN connector you wish to use for Dante connections.

2. Connect a cable (Cat5/6e or fiber) to the LAN connector that is designated for Dante. Connect the other end to a switch on your Dante network.
3. Open the Dante Controller and check that the network interface details are correct.

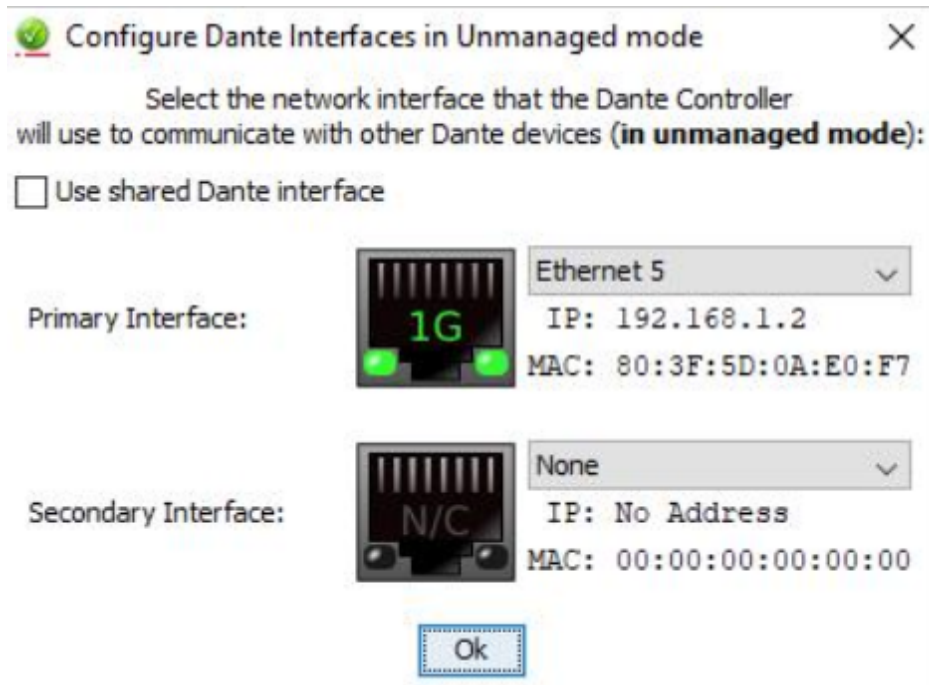

4. Check network and connection details under the **Status** tab in the CCM.



- Details can also be viewed in the Dante Controller.

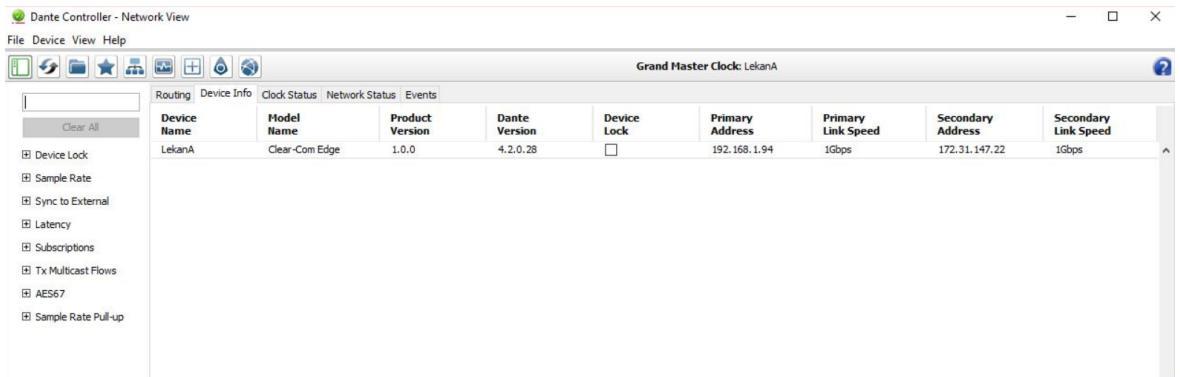

- Route the channels as required in the Dante Controller.
- You will see available Dante ports in the **Configuration** page of the CCM. These ports can be assigned to channels on the Arcadia Central Station in the usual way.
- Select the required channel click the **+** icon next to the port.

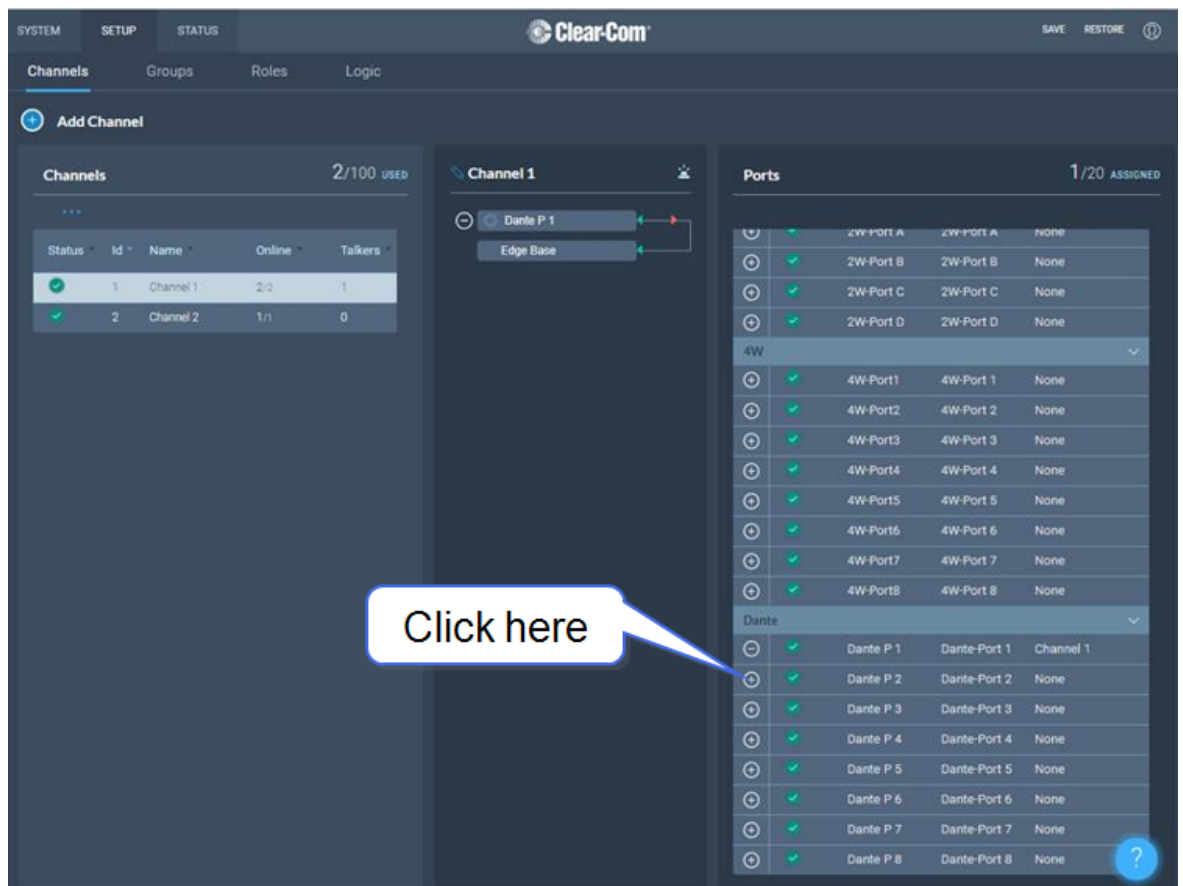



# 9 Configuring from the CCM

This chapter describes how to use the CCM to set up, configure and monitor your intercom system. It contains the following sections:

- 9.1 Configuring Station Settings ..... 74
- 9.2 Adding IP Transceivers (FS Edge, FS II 1.9) ..... 79
- 9.3 Registering Beltpacks ..... 80
- 9.4 Channels and Groups ..... 82
- 9.5 Managing Channels ..... 84
- 9.6 Managing Groups ..... 88
- 9.7 Creating and Editing Roles ..... 94
- 9.8 Setting up GPIOs and Logic Events ..... 99
- 9.9 Monitoring System Status ..... 102

---

## 9.1 Configuring Station Settings

To configure the Arcadia Central Station, click anywhere on the **Hosts** panel under **Hardware > Resources**.

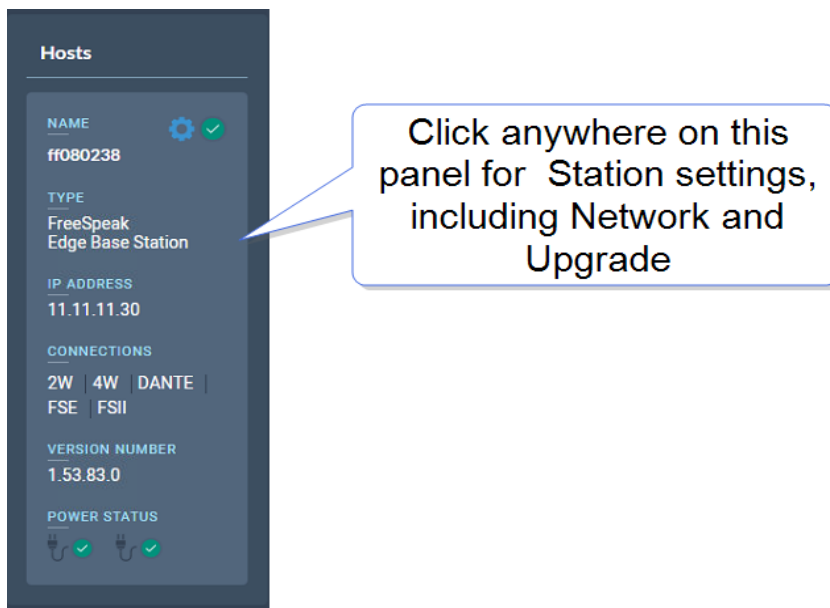

Here you can:

- Configure the network
- Upgrade the Arcadia Central Station and connected resources
- Change the following wireless beltpack system settings:
  - Administration pin numbers
  - FS Edge wireless region (important for system compliance)
  - FSII battery type, if you are not using the supplied Li-ion batteries you may use Alkaline or NiMH type batteries
- Configure security settings
- Add new licenses (only for the Arcadia Central Station)

Click the pencil icon  to name your Arcadia Central Station .

### 9.1.1 Configuring the Network

After changing the network configuration, you must click **Apply** or [Enter] key.

For information see: [Arcadia Central Station LAN Configuration Rules on page 61](#).

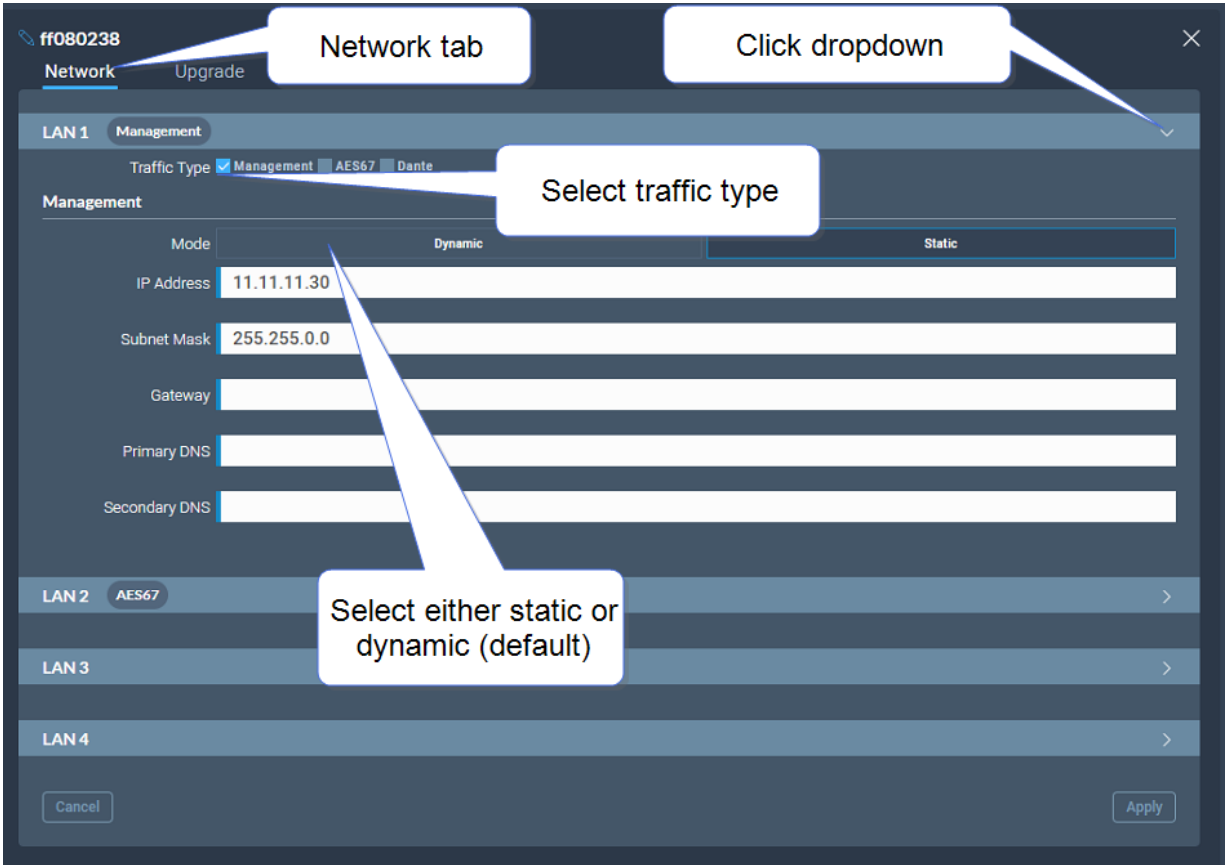

## 9.1.2 Upgrading

To upgrade the Arcadia Central Station and connected resources:

1. Select the **Upgrade** tab.
2. **Select File** then navigate to where the upgrade file is stored on your computer.
3. Select the file and when the **Upgrade** button lights, click it. This begins the upgrade process.

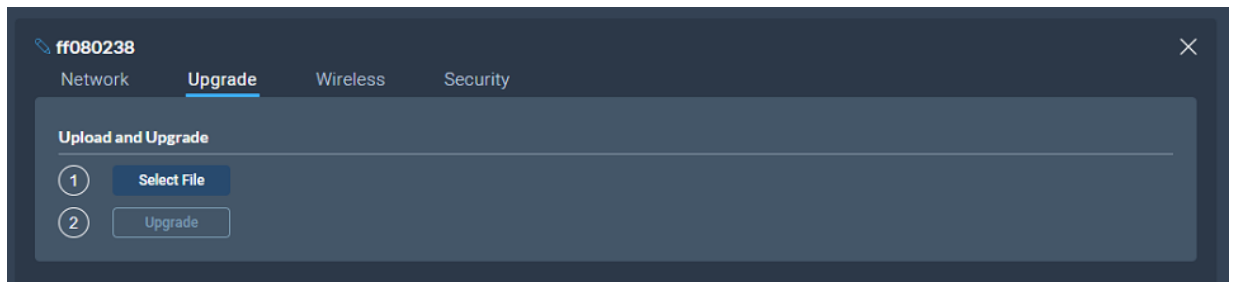

Device to upgrade	File extension
Arcadia Central Station, FS II IP TCVR, FS Edge IP TCVR	.ccf
FS II beltpack, FS II E1 TCVR	.fww
FS Edge beltpack	.ccu

## 9.1.3 Setting Up the Wireless Beltpack System

Select the **Wireless** tab.

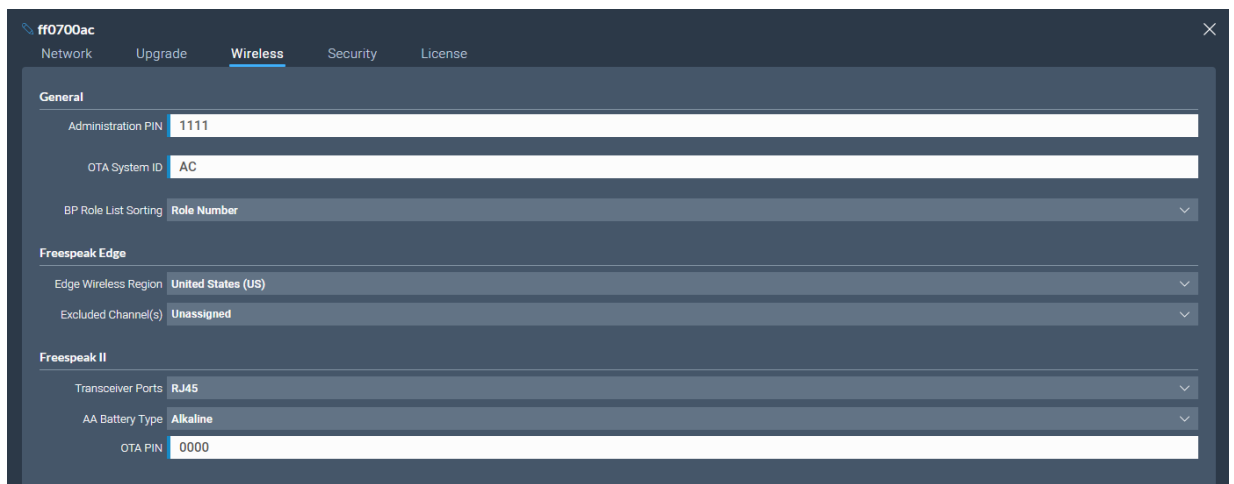

From the Wireless tab, you can set or view the following System and Station settings.

## System

- The administration pin for your wireless system, used by the beltback to be able to access privileged functionality
- System ID. This is used to differentiate this system's RF signals from those of other systems
- Beltback role list sorting:
  - Role number
  - Alphabetical

## FreeSpeak Edge

- The wireless region for your FreeSpeak Edge beltbacks. The region set here **MUST** match the hard-coded setting on your Edge transceiver or the system will not work. You will see an error flag in the **Status** page if the regions do not match. Please contact your Clear-Com representative if you have any difficulties with this.
- Select from a list of 5 GHz channels that you can exclude and prevent transceivers from using.

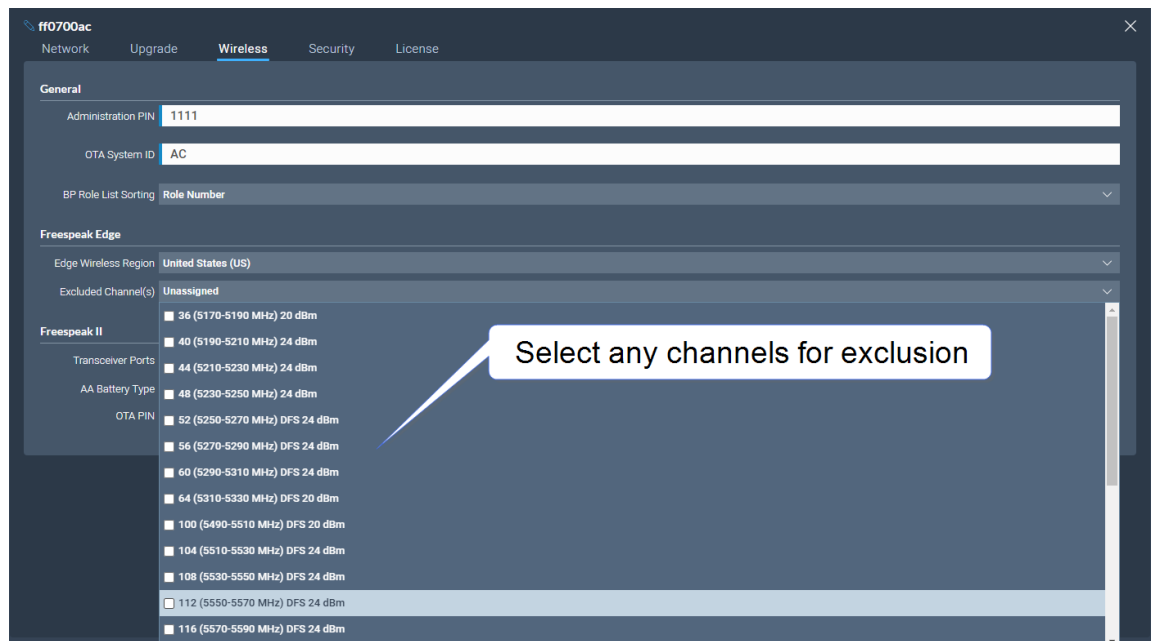

## FreeSpeak II

- AA Battery type. You can choose not to use the Li-ion batteries supplied with the beltpacks, in which case you must specify battery type here. Choose between:
  - Alkaline (AA) batteries (default setting)
  - NiMH batteries for use in settings where air pressure is an issue (for instance on an underwater site).
- The OTA pin you need for over-the-air (OTA) registration of your FreeSpeak II beltpacks.

## 9.2 Adding IP Transceivers (FS Edge, FS II 1.9)

**Note:** To add E1 transceivers, see [Connecting Transceivers Over E1 on page 50](#).

To add IP transceivers:

1. Navigate to **Hardware > Resources** and select **Add Resource**. The following screen appears.

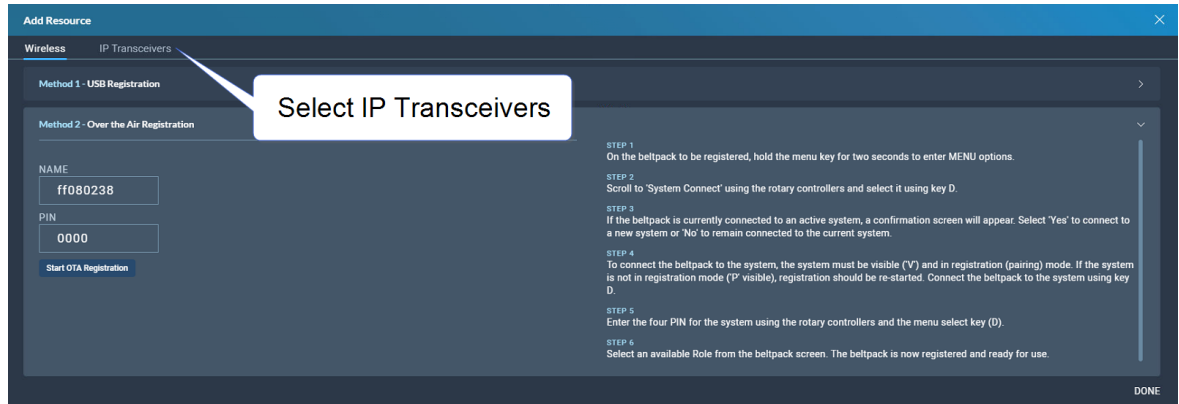

2. Select **IP Transceivers**. The following screen appears:

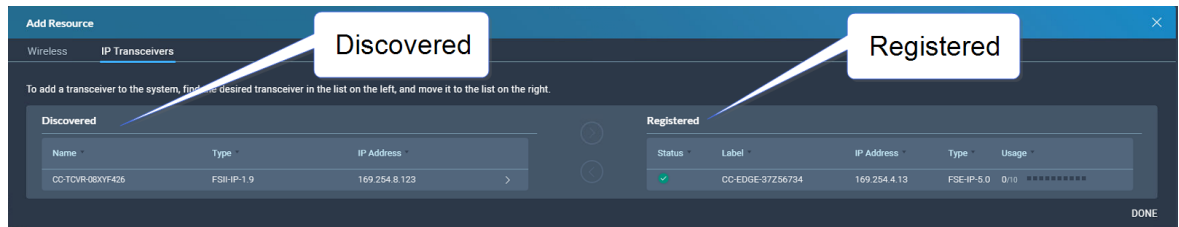

3. Select the transceiver that you want to register from the left-hand area of the screen, and click the right-hand arrow.

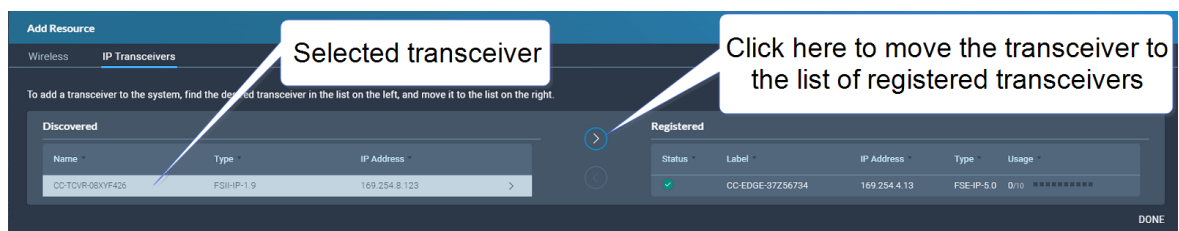

The selected transceiver appears in the right-hand list of registered transceivers.

## 9.3 Registering Beltpacks

Before you can use a beltpack, you must register it. This enables the Arcadia Central Station to associate the beltpack with roles and assigned keys.

You can register a beltpack in two ways:

- By USB cable. When registering a beltpack in this way, a role that assigns keys to the beltpack is automatically created and fixed to the beltpack. The role can be edited as required in the **Configuration > Roles** page of the CCM.
- Over The Air (OTA). When you register a beltpack in this way you must create a role for it manually in **Configuration > Roles** before the beltpack can connect.

### 9.3.1 Registering a beltpack by USB cable

This method of registering beltpacks is recommended for fast and easy set up.

To register a beltpack using a USB cable, connect a beltpack to Arcadia Central Station using a USB A to micro USB B (FSII) / USB C (FSE) cable. The beltpack can be powered on either before or after connection. The Arcadia Central Station will show 'Beltpack [ID] is now registered' in the front menu screens.

**Note:** *When beltpacks are registered in this way, a role with two channels (1 and 2) is automatically generated and applied to the beltpack. Roles can be edited at any time in the **Configuration** page of the CCM.*

### 9.3.2 Registering a beltpack OTA

To register a beltpack using OTA:

1. Navigate to **Hardware > Resources** and click **Add Resource**. The following screen appears:



The screenshot shows a web interface for adding resources. At the top, there's a blue header 'Add Resource'. Below it, there are two tabs: 'Wireless' (selected) and 'IP Transceivers'. Under 'Wireless', there are two sub-sections: 'Method 1 - USB Registration' and 'Method 2 - Over the Air Registration'. The 'Over the Air Registration' section is active and contains two input fields: 'NAME' with the value 'ff445566' and 'PIN' with the value '0000'. Below these fields is a blue button labeled 'Start OTA Registration'. Two callout boxes are present: one pointing to the 'Over the Air Registration' header with the text 'Select Over the Air Registration', and another pointing to the 'Start OTA Registration' button with the text 'Select Start Over the Air Registration'.

2. Click **Start OTA Registration**.

**Note:** *A timer is started indicating how long the system is open for registration. You can close OTA registration on the system at any point.*

## 9.4 Channels and Groups

Channels and groups are both essentially digital containers for audio sources, allowing communication between members.

### 9.4.1 Channels

A Channel operates as an intercom Partyline or conference. All members can talk to and listen to all other members, as long as they have keys to do so.

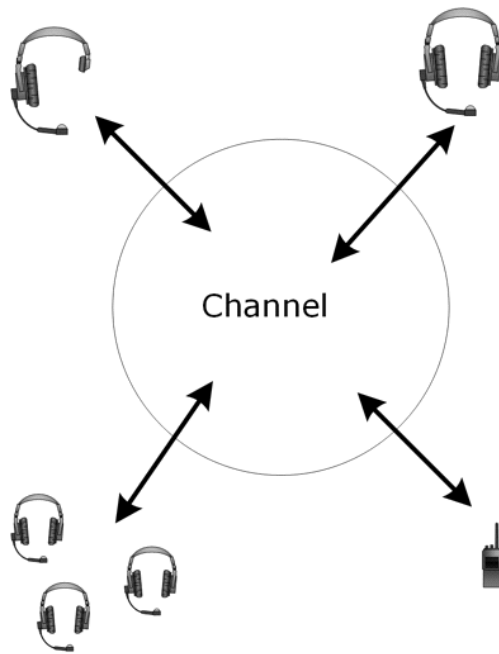

The default key behavior setting for a wireless beltpack in a Channel is **Talk and Forced Listen**. For more information, see **Key Behavior**.

## 9.4.2 Groups

A Group configuration enables an announcement or broadcast to a number of members at the same time.

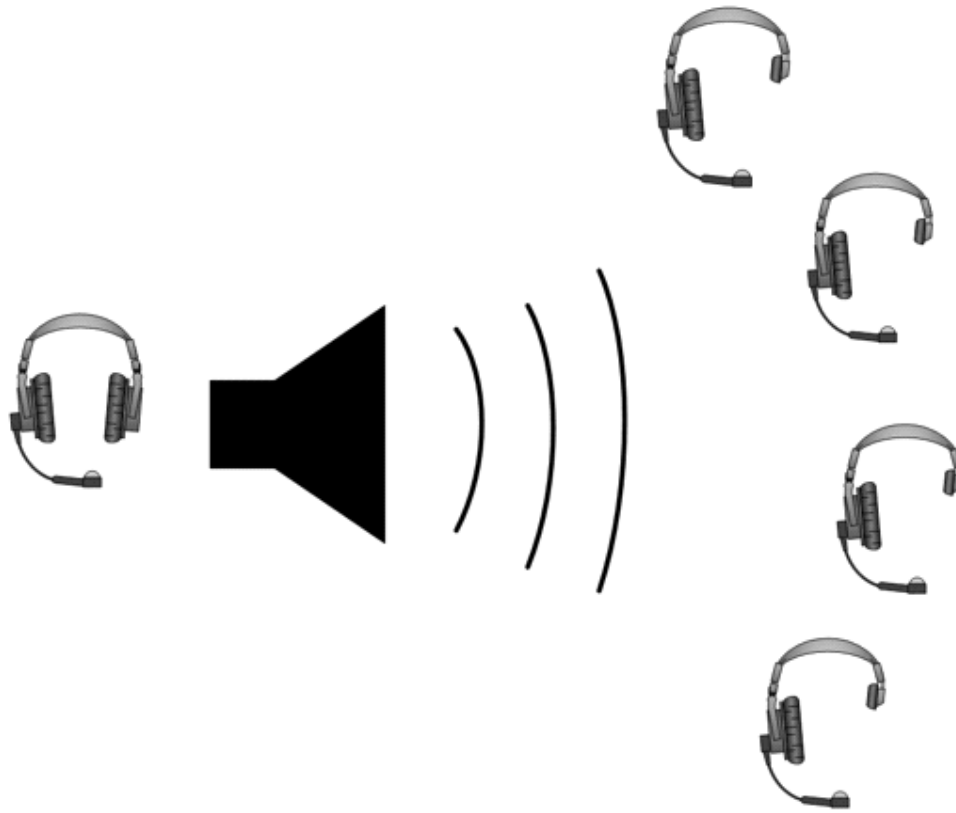

A group member can reply directly to the announcer using the **Reply** key. The other group members will not hear this.

To set up a group, you must first put the members in the Group. Then, when the members are in the Group, you can set up a key or keys to talk to it.

# 9.5 Managing Channels

From the **Channels** tab, you can:

- View existing channels and add or remove new channels.
- View existing ports, and add or remove ports from the channel.

To access the **Channels** screen, navigate to **Configuration > Channels**. The Channels screen appears.

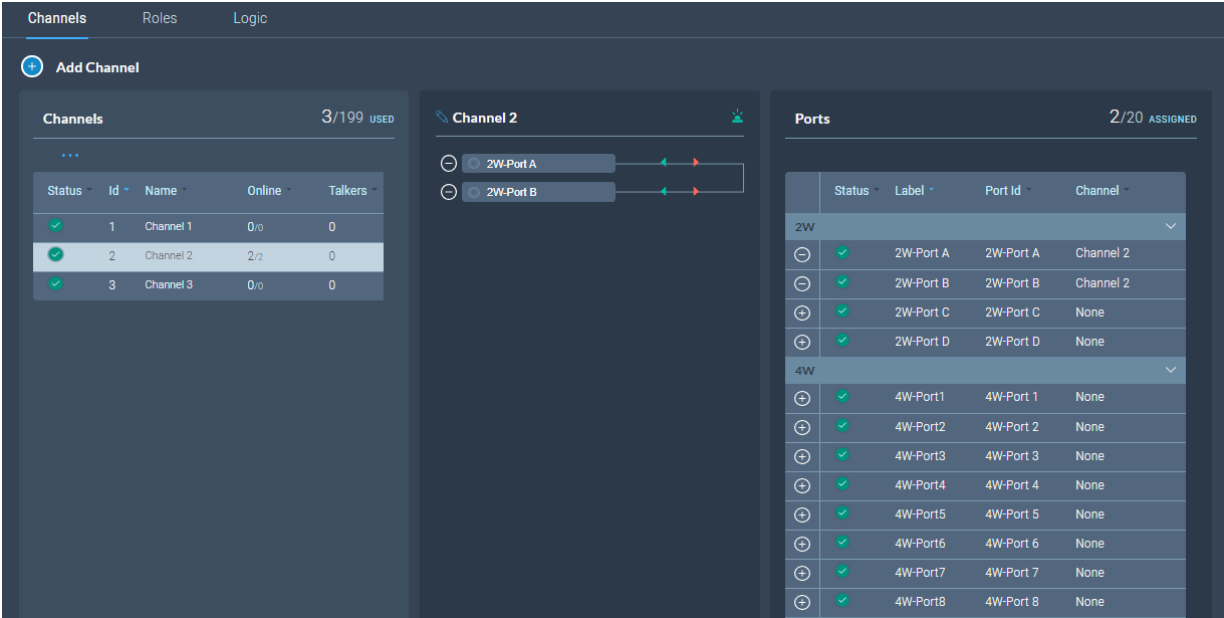

## 9.5.1 Viewing Information About a Channel

When you open the **Channels** screen, the left-hand panel displays a list of all the channels that are currently present. The following information is displayed for each channel.

The screenshot shows the 'Channels' list with callout boxes explaining the information displayed for each channel:

- Click this icon to delete a channel:** Points to the minus sign icon in the top left of the Channels panel.
- A green tick mark indicates that all configured ports are connected:** Points to the green checkmark in the Status column.
- This indicates how many users are talking on this channel:** Points to the 'Talkers' column.
- The channel count indicates that eight out of a maximum of 100 channels:** Points to the '8/100 USED' text.
- This is a label for the channel:** Points to the 'Name' column.
- This indicates how many configured ports are connected:** Points to the 'Online' column.

## Status

A green tick mark indicates that all the ports that are configured for the channel are connected. Otherwise, a warning triangle is shown.

## Name

This field contains a label that enables you to identify the channel.

**Note:** A label can contain up to 10 characters. You can edit this label from the center panel.

## Online

This indicates how many of the total channel members are online.

## Talkers

This indicates how many members have active talk routes on this channel.

## 9.5.2 Adding a New Channel

To add a new channel:

1. Click the new channel icon . A new entry appears in the list of added channels.

**Note:** You can only add new channels up to a maximum number (100).

2. Add any required ports to the channel.

### 9.5.3 Adding Ports to a Channel

To add ports to a channel:

1. From the **Channel** panel, select the channel in which the port is to be added.
2. From the **Ports** panel, click the add port icon  of the port that you require.

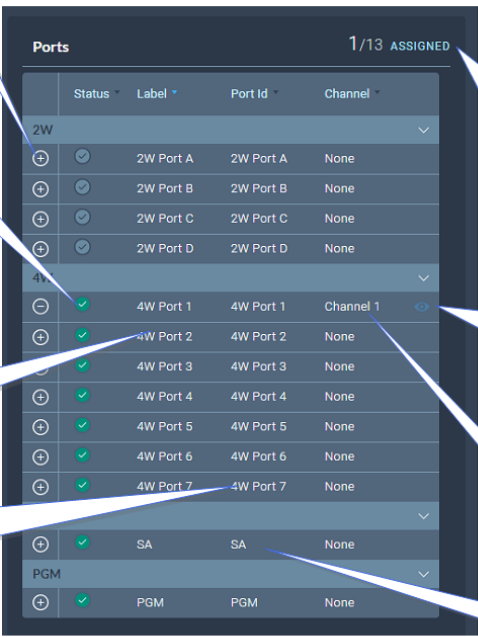

Click here to add this port to a channel

A green checkmark indicates that the port is online

This is a label that helps you to identify the port

This identifies the port. Changing the label does not affect the Port Id

This indicates how many of the total number of ports are assigned to the currently selected channel

Click on the eye icon to highlight the channels that the port is assigned to

This is the name of the channel that the port is currently assigned to

Stage Announce

Status	Label	Port Id	Channel
<b>2W</b>			
+	2W Port A	2W Port A	None
+	2W Port B	2W Port B	None
+	2W Port C	2W Port C	None
+	2W Port D	2W Port D	None
<b>4W</b>			
+	4W Port 1	4W Port 1	Channel 1
+	4W Port 2	4W Port 2	None
+	4W Port 3	4W Port 3	None
+	4W Port 4	4W Port 4	None
+	4W Port 5	4W Port 5	None
+	4W Port 6	4W Port 6	None
+	4W Port 7	4W Port 7	None
<b>SA</b>			
+	SA	SA	None
<b>PGM</b>			
+	PGM	PGM	None

The port is now added to the channel, and appears in the list of ports in the center panel.



Click here to edit the channel label

Click here to remove the port from the channel

This is the label of the port

When this is lit it indicates that a call signal is active in this channel

The green arrows indicate active listen (left arrow). The red arrows indicate active talk (right arrow).

## 9.5.4 Removing Ports From a Channel

To remove a port from a channel:

1. From the **Channels** panel, select the required channel.

2. Click the remove icon  of the port that you want to remove.

The port is removed.

## 9.5.5 Deleting a Channel

To delete a channel:

1. From the **Channels** panel, select the channel that you want to delete.
2. Remove all the ports from the channel

**Note:** *If you do not remove the ports, you will be prompted to do so in step 3.*

3. Click the **More Actions** icon , and select **Delete**.

## 9.6 Managing Groups

From the **Groups** tab, you can:

- View existing groups and add or remove new groups.
- View existing ports, and add or remove ports from the groups.

**Note:** *Belpacks are added to Groups in the Roles page.*

To access the **Groups** screen, navigate to **Configuration > Groups**. The Groups screen appears:

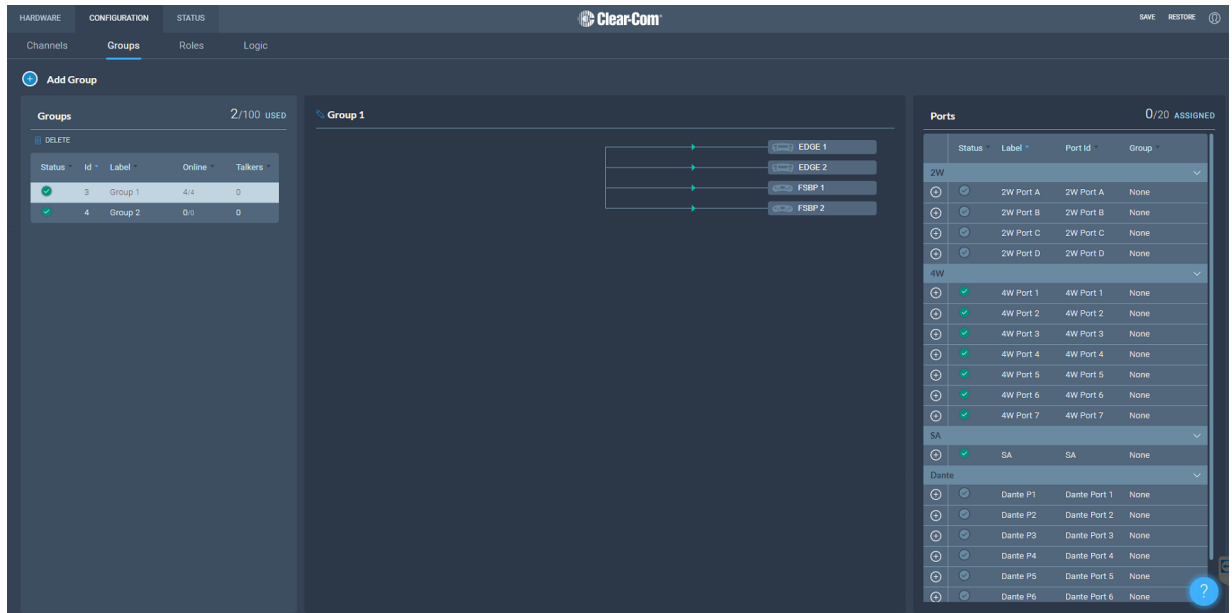

### 9.6.1 Viewing Information About a Group

When you open the **Groups** screen, the left-hand panel displays a list of all the groups that have been created. The following information is displayed for each group.





## Status

A green tick mark indicates that all the ports that are configured for group are connected. Otherwise, a warning triangle is shown.

## Name

This field contains a label that enables you to identify the group.

**Note:** A label can contain up to 10 characters. You can edit this label from the center panel.

## Online

This indicates how many of the total group members are online.

## Talkers

This indicates how many FS II beltpacks or logic-routed ports have active talk routes on this group.

## 9.6.2 Adding a New Group

To add a new group:

1. Click the new group icon . A new entry appears in the list of added groups.  
**Note:** You can only add new groups up to a maximum number (100).
2. You can now add any required ports and members to the group.

### 9.6.3 Adding Ports and Roles to a Group

To configure a group you must first put the members in the group. These can be ports and/or roles. When you have done this you will configure a talk key to the group (group administrator).

#### Adding Ports to a Group

1. From the **Group** panel, select the group in which the port is to be added.
2. From the **Ports** panel, click the add port icon  of the port that you require.

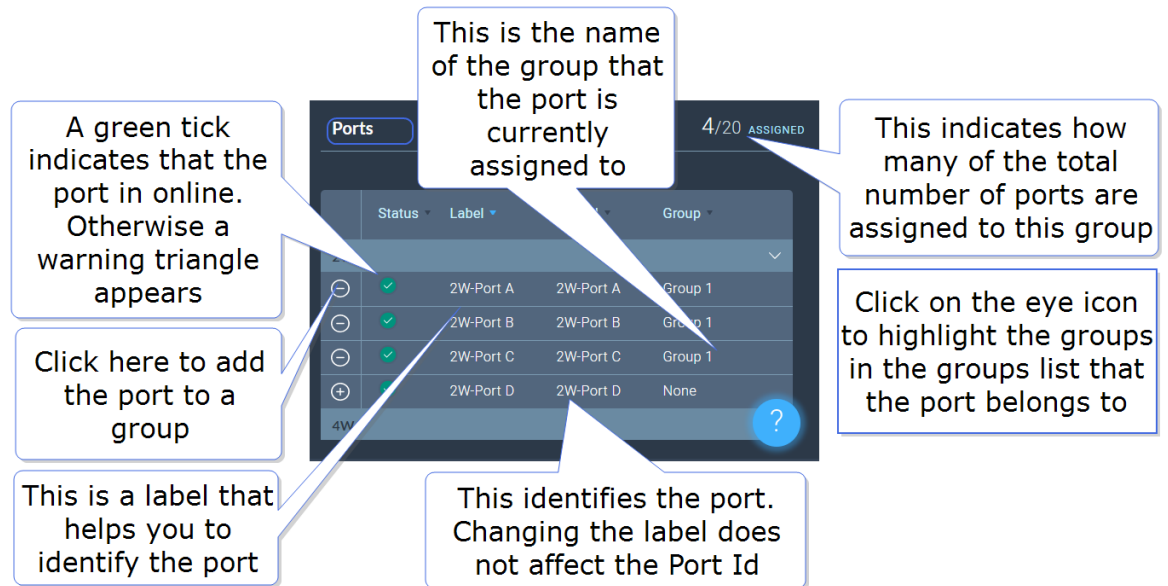

The port is now added to the group, and appears in the list of ports in the center panel.

#### Adding Roles to a Group

1. In the **Roles** page, select the role you wish to add to the group.
2. On the left side of the screen, select **Group Membership**.

**Group Membership**

Group Membership **Unassigned** 

**Headset**

Limiters **0 dB** 

Sidetone Gain **-12 dB** 

Sidetone Control **Tracking** **Non-Tracking** **Disabled**

Headphone Detect **Enabled** **Disabled**

Headset Mic Type **Dynamic** **Electret**

*Note: A callout bubble points to the grid icon with the text "Add role to a group".*

## Configuring a Talk Key to the Group

1. In the **Roles** page, select the role you want to talk to the group.
2. Configure a talk key to the group (Talk Only)

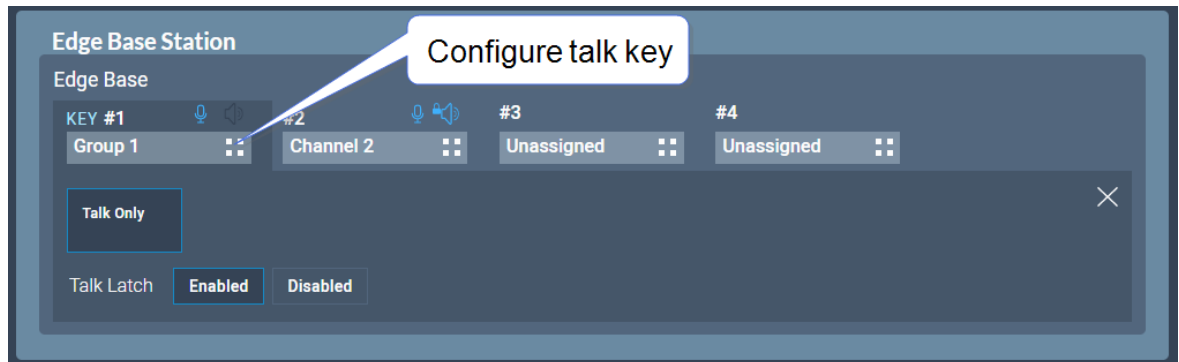

When you have configured members and a talk key to a group, you will see the group by selecting it in the **Groups** page. The group administrator will talk to the whole group. The group members can talk directly back to the group administrator using the **Reply** key. This communication will not be broadcast to the group, only the administrator will hear.

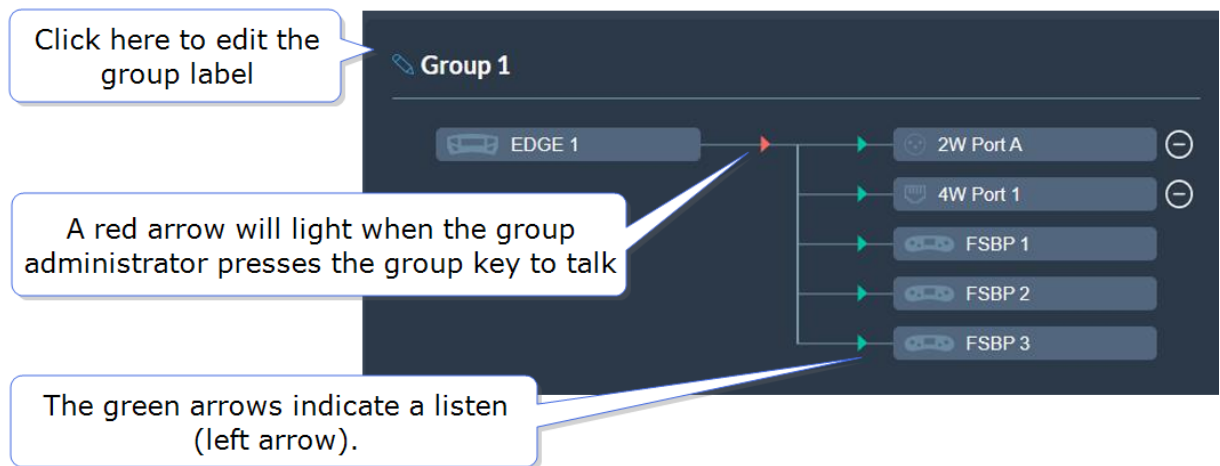

### 9.6.4 Removing Ports from a Group

To remove a port from a group:

1. From the **Groups** panel, select the required group.

2. Click the remove icon  of the port that you want to remove.

The port is removed.

## 9.6.5 Deleting a Group

To delete a group:

1. From the **Groups** panel, select the group that you want to delete.
2. Remove all the ports from the group

**Note:** *If you do not remove the ports, you will be prompted to do so in step 3.*

3. Click the trash can icon. The group is deleted.

## 9.7 Creating and Editing Roles

From the **Roles** page, you can view, add, edit, clone or delete roles.

### 9.7.1 Viewing Roles

To view roles, navigate to **Configuration > Roles**. The following screen appears.

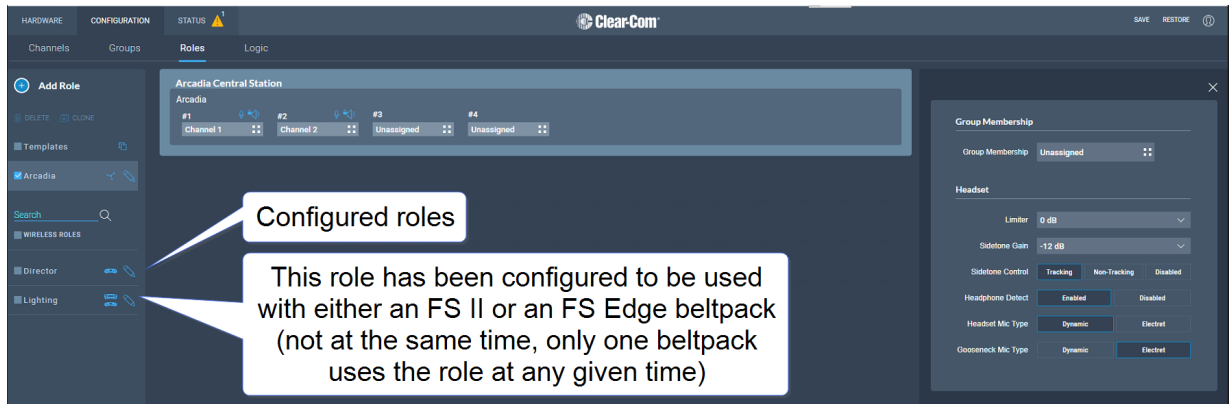

A list of roles appears on the left-hand side of the screen.

### 9.7.2 Adding Roles

To add roles:

1. Navigate to **Configuration > Roles**.

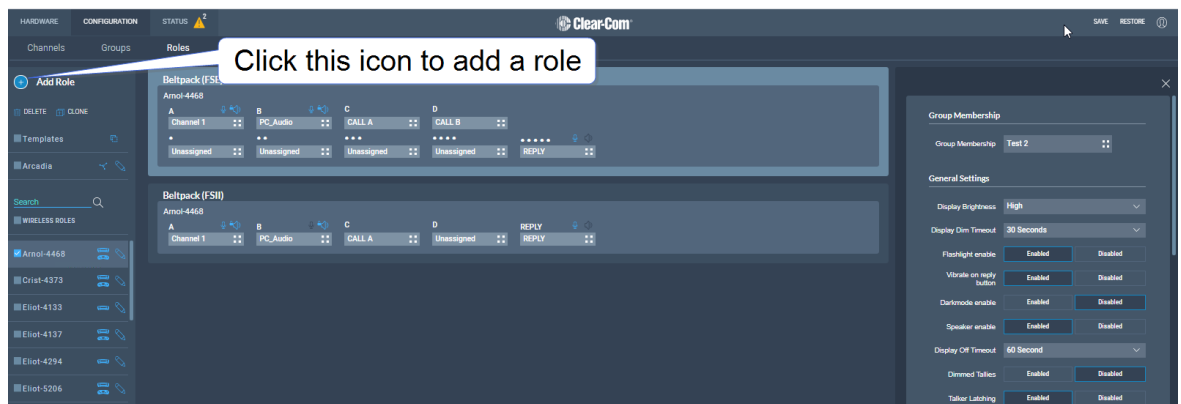

2. Click **Add Roles**. The following screen appears.

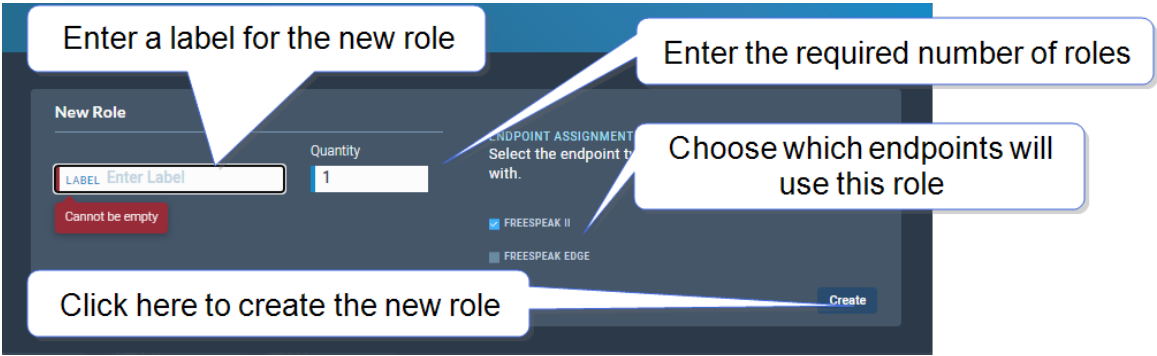

- 3. Enter a label for the role, the number of roles required and choose which endpoints will use this role (FS II, FS Edge or both). Only one backpack can use the role at a given time.

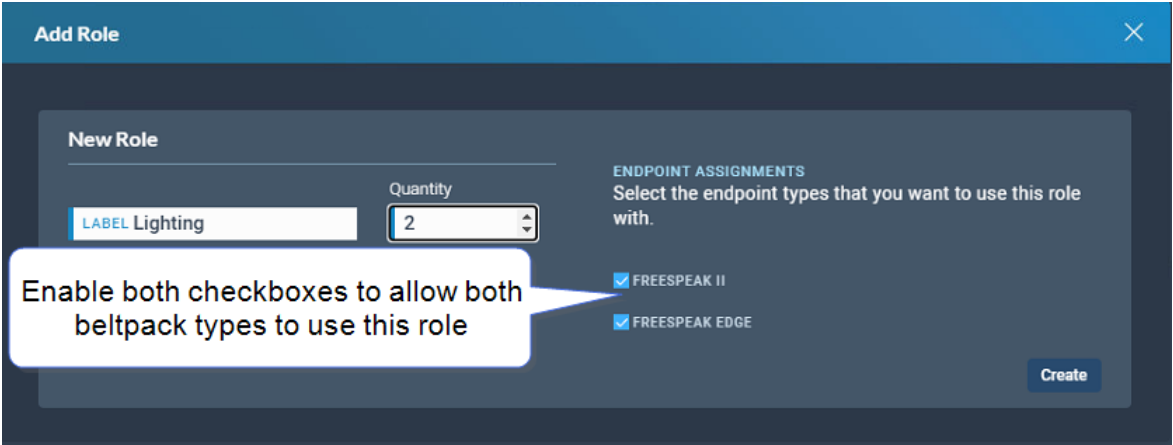

**Note:** When creating multiple roles, the system will add an incrementing numerical suffix to the role name. Roles names must be unique.

**Note:** You can also edit the label and endpoint assignments from the icons that appear beside each role in the left-hand side of the screen.

- 4. Click **Create**. The new role appears in the list of roles in the left-hand side of the **Roles** screen.

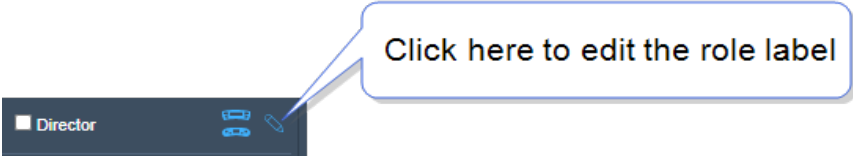

## 9.7.3 Editing Role Key Assignment

1. Navigate to **Configuration > Roles** and select required role on the left of the screen.
2. Click on the small white squares.

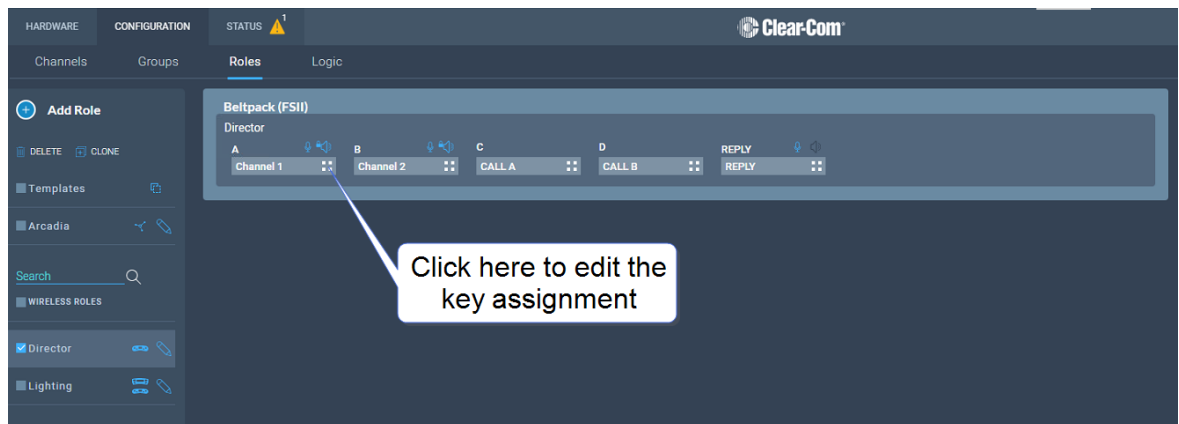

The key assignment screen appears.

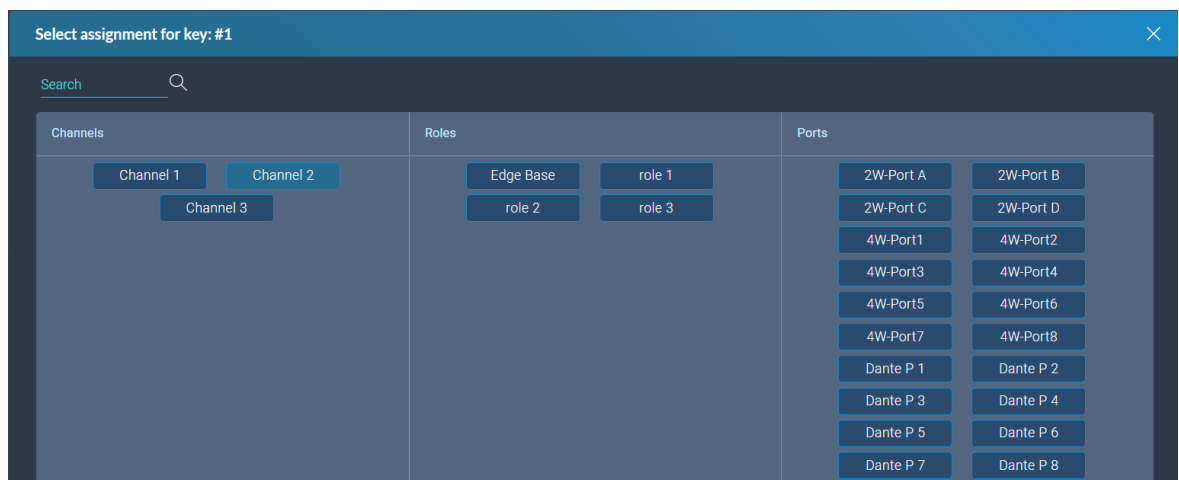

3. Click to select the required audio source.

## 9.7.4 Configuring Role Settings

To configure the settings for a role:

1. Navigate to **Configuration > Roles**, and select the required role from the list of roles in the left-hand side of the screen.
2. From the **Settings** panel on the right-hand side of the screen, scroll to the required setting.
3. Edit the setting as required.



## 9.7.5 Cloning Roles

To clone roles:

1. Navigate to **Configuration > Roles**, and select the role that you wish to clone from the list of roles in the left-hand side of the screen.
2. Click **CLONE**.

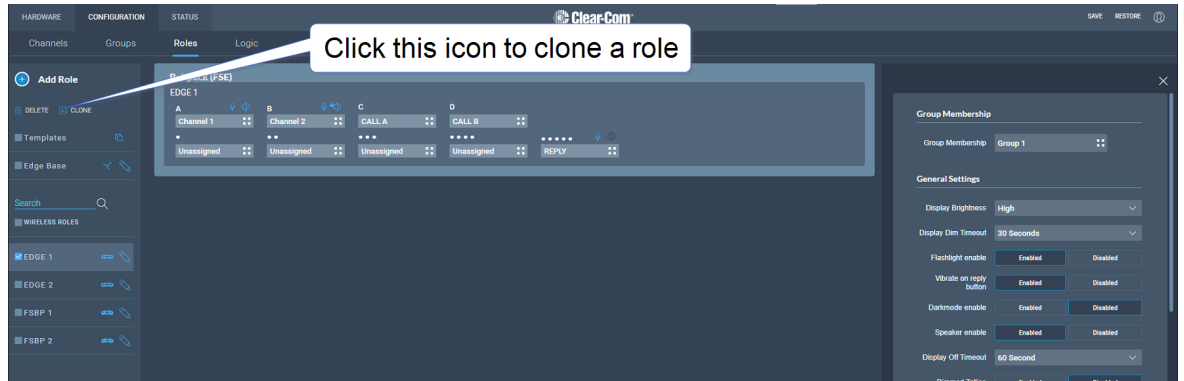

The role is cloned and added to the list of roles in the left-hand side of the screen.

## 9.7.6 Deleting Roles

To delete roles:

1. Navigate to **Configuration > Roles**, and select the role that you wish to delete from the list of roles in the left-hand side of the screen.
2. Click **DELETE**.

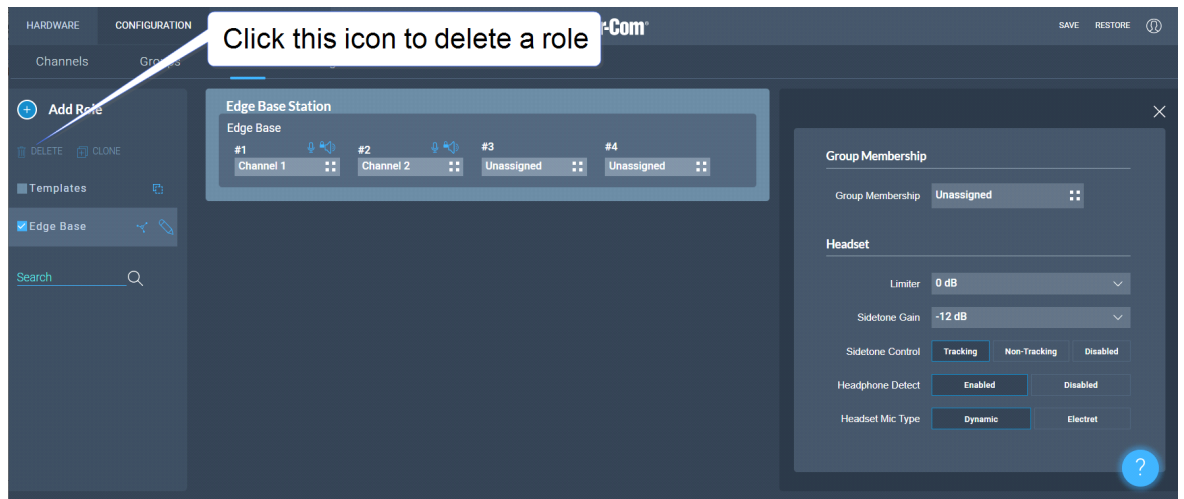

The role is deleted and removed from the list of roles in the left-hand side of the screen.

## 9.7.7 Setting Key Behavior

Audio keys can be set to different Talk and Listen states. These key behavior states apply to the keys on the Arcadia Central Station and beltpacks and panels. Key behavior is configured in the **Roles** tab in the CCM. See [Creating and Editing Roles on page 94](#).

Key Behavior Options	Resulting Audio Behavior
Talk-Only	Press key to talk. Key only controls talk.
Listen-Only	Press key to listen. Key only controls listen.
Talk and Listen	Press key to talk and listen.
Dual Talk and Listen (beltpacks only)	Press key to talk and listen. Listen latches on or off according to preference (quick tap to latch). The user can push and hold (PTT) to activate talk.
Force Listen	Permanent listen.
Talk and Forced Listen	Permanent listen, push key to talk.
Force Talk and Force Listen (beltpacks only)	Permanent listen and talk.

## 9.8 Setting up GPIOs and Logic Events

### 9.8.1 Overview

- 2 x GPIs
- 4 x GPOs
- Unlimited Logic Events
- Each GPI/GPO hosts up to 10 different events or actions. These actions can be turned off or on in the **Status > Logic** page of the CCM.
- 2 x DB 9F connectors on the rear of the Arcadia Central Station (C). See [Rear Panel Connectors and Indicators on page 22](#).
- For DB 9F pinouts, see [Pinouts on page 141](#)

### 9.8.2 Examples of GPIs

On an input from an external device, an audio route can be established between two entities.

- If an on-air light comes on, the program feed (**PGM**) can be routed to a Channel or beltpack.
- Use a footswitch to allow the station user to open an audio route to a Channel.
- On an input from a two-way radio, an audio route can be established to a channel (the radio talks to the channel).

### 9.8.3 Examples of GPOs

GPOs are triggered (sent to an external device) when a **Talk**, **Talk & Listen** or a **Call** comes into a named entity.

- When someone talks to stage announce, an output relay (GPO) is sent to the external stage announce speaker.
- When someone talks to a channel labeled Radio, an output is sent to a 2-way radio.
- When a call signal (**Call**) comes into a channel, and output is sent to turn on an on-air light.

### 9.8.4 Examples of Logic Events

- An output can be triggered on a crosspoint activation (when someone presses a talk key).
- An input can be used to trigger a call signal.

## 9.8.5 Configuring GPIs

This example opens a talk route from the Arcadia Central Station to a Channel when an input occurs on GPI1 (for instance, from a footswitch).

Navigate to **Configuration > Logic**.

1. On the left panel, click GPI1 to select it.



2. Click the Add button  in the center panel.

3. Click the Options button  to select a **Source**. Select **Arcadia**.

4. Click the Options button  to select a **Destination**. Select the required Channel.

5. Click the blue check mark.

6. To label the GPI, click the pencil icon.

7. To test the GPI, or turn it on and off, navigate to **Status > Logic**. See: [Logic Page on page 38](#).

## 9.8.6 Configuring GPOs

In this example you will send an output trigger (for example to an external stage announce speaker) on GPO1 when **Talk** is activated on stage announce (**SA**).

1. Navigate to **Configuration > Logic**.

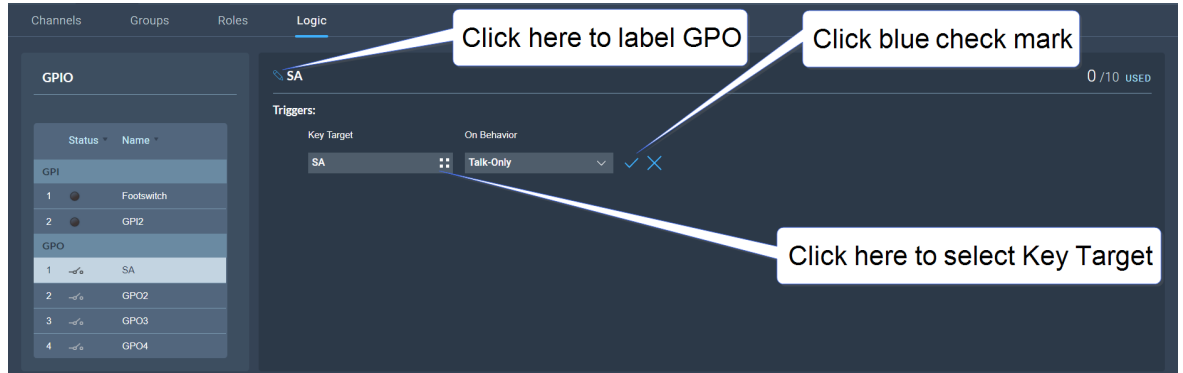

2. On the left panel, click GPO1 to select it.

3. Click the Add button  in the center panel.

4. Click the Options button  to select a **Key Target**. Select stage announce (SA).

5. In this case, the **On Behavior** field defaults to **Talk Only**.

6. Click the blue check mark.

7. To label the GPO, click the pencil icon.

8. To test the GPO, navigate to **Status > Logic**. See [Logic Page on page 38](#).

# 9.9 Monitoring System Status

You can monitor your system using the following features of the CCM:

- Overview
- Event Log
- Logic

## 9.9.1 Overview

To see the **Overview** screen, navigate to **Status > Overview**. The following screen appears.

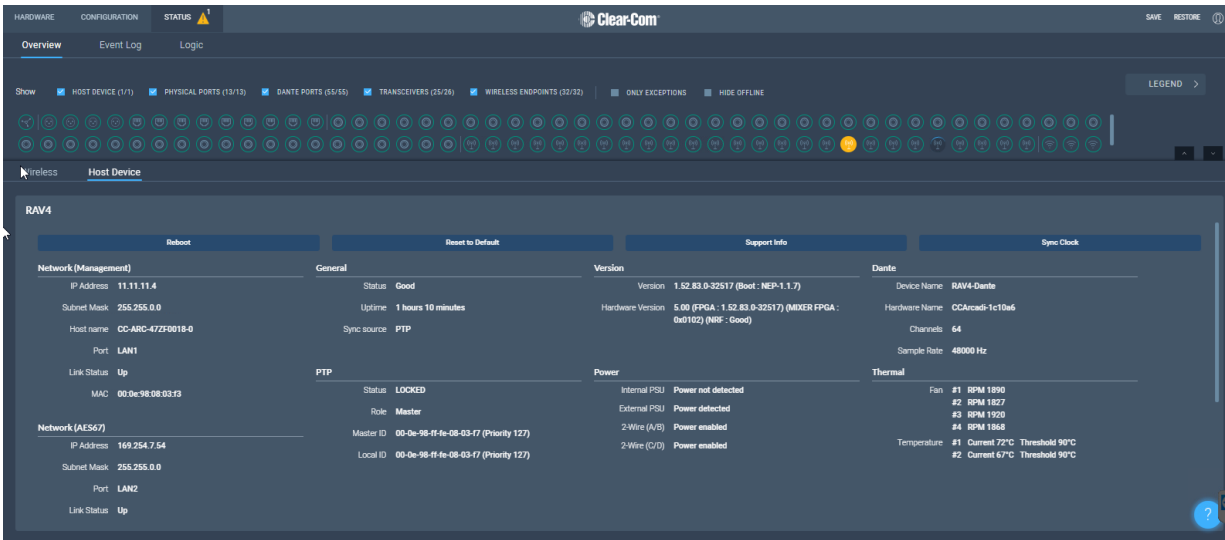

The **Overview** screen consists to two sections. There is an upper section that displays a list of system icons representing the ports, transceivers and endpoints and a lower section that gives detailed information about each connected device and about the Arcadia Central Station.

**Note:** *There is currently no detailed status for 2W, 4W and Dante.*

## 9.9.2 System Icons

Each icon is color-coded to give an easily accessible view of the status of each entity.

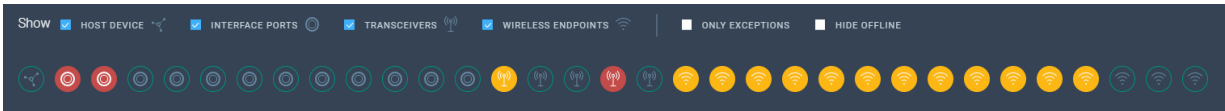

The following legend is used to indicate the status of each entity.

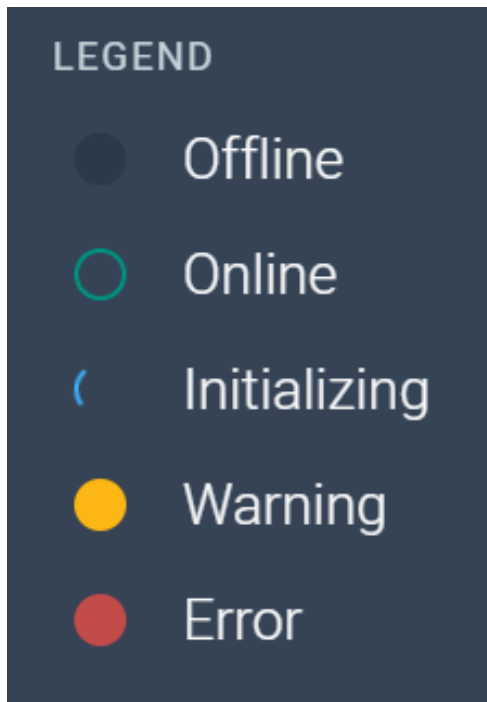

### 9.9.3 Monitoring Wireless Devices

Navigate to **Status > Overview > Wireless**. This section of the **Overview** screen lists all the wireless devices connected to your system, and gives the following information for each device:

- Associated role
- Type of transceiver
- Battery level
- Signal strength
- Volume setting
- Remote Microphone Kill (RMK) button to mute all microphones connected to your system.
- Call button to send a text message to all connected devices.
- Network and PTP status of transceivers
- Reboot transceiver

Wireless										Host Device										
Device Name *	Role *	Type	Battery	Signal	Keys	Vol.	RMK All	Call All	TC1/R1	TC1/R2	TC1/R3	TC1/R4	TC1/R5	TC1/R6	TC1/R7	TC1/R8	TC1/R9	TC1/R10	CC-EDGE-37Z56734	CC-TCVR-08XYF426
EDGE-BP-524291	EDGE 1	FSE 5.0	<div style="width: 100%;"></div>	<div style="width: 100%;"></div>	<div style="width: 100%;"></div>	<div style="width: 100%;"></div>	RMK	Call	0/0	0/0	0/0	0/0	0/0	0/0	0/0	0/0	0/0	0/0	2/10	2/10
EDGE-BP-524338	EDGE 2	FSE 5.0	<div style="width: 100%;"></div>	<div style="width: 100%;"></div>	<div style="width: 100%;"></div>	<div style="width: 100%;"></div>	RMK	Call											2/10	
FSII-BP-15901	FSBP 2	FSII 1.9	<div style="width: 100%;"></div>	<div style="width: 100%;"></div>	<div style="width: 100%;"></div>	<div style="width: 100%;"></div>	RMK	Call												2/10
FSII-BP-16231	FSBP 1	FSII 1.9	<div style="width: 100%;"></div>	<div style="width: 100%;"></div>	<div style="width: 100%;"></div>	<div style="width: 100%;"></div>	RMK	Call												2/10

### Transceiver details

View details. Scroll down here to reboot the transceiver.

Select a transceiver to see network, version and PTP details.

PTP details

Network	Value
AES67 Admin IP Address	169.254.8.123
AES67 Audio IP Address	169.254.8.128
Subnet Mask	255.255.0.0
Network Mode	DHCP
Version	Value
Version	4.8.67.0
Radio Version	0107
FPGA Version	v.0.6.2-b46/v.2.3.4-b100-c2
PTP	Value
Status	Locked
Role	Slave
Master ID	00-0e-98-ff-fe-08-02-3a (Priority 127)
Local ID	00-0e-98-ff-fe-02-fe-77 (Priority 234)
Offset from Master	20 ns (max 47 ns)
Mean Path Delay	6,600 ns +/- 3
Mean Frequency	-1 ppb +/- 27



### Monitoring Beltpack Details

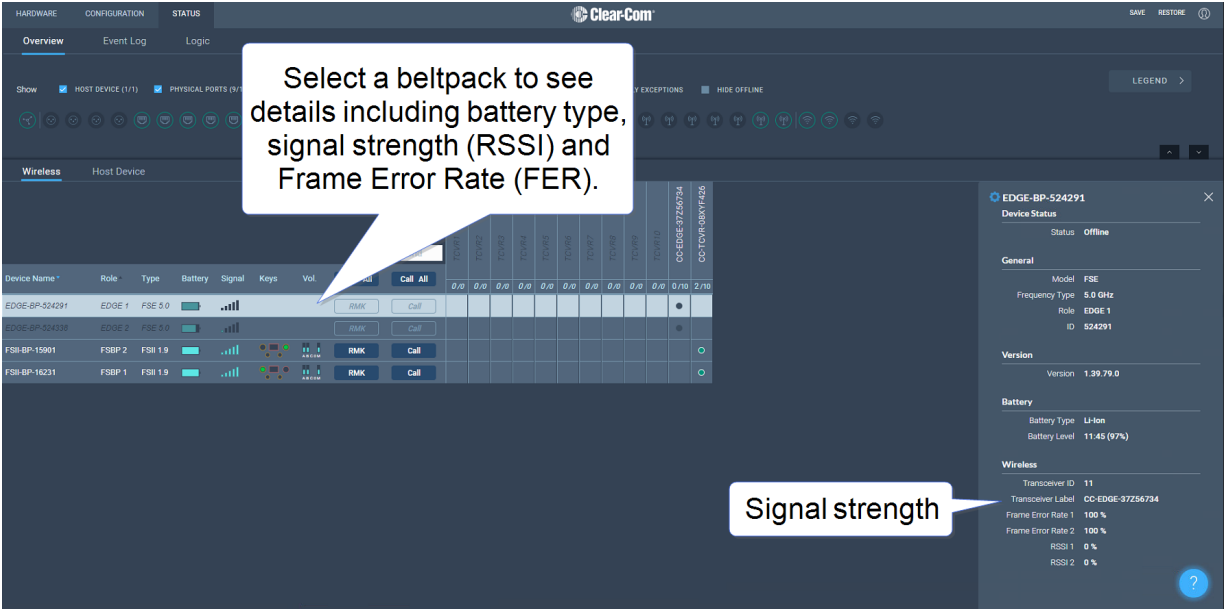

### 9.9.4 Monitoring the Host Device

Navigate to **Status > Overview > Host Device**. A screen appears that gives information about the Arcadia Central Station and enables various procedures including:

- Reboot
- Reset to Default
- Collect Support Info
- Sync Clock
- Network
  - Management
  - AES67
  - Dante
- General
  - Status
  - Uptime
  - Sync Source
  - Version
- PTP
- Power to the Arcadia Central Station
- Thermal

The screenshot shows the Clear-Com web interface for a host device. At the top, there are tabs for HARDWARE, CONFIGURATION, and STATUS. Below these are sub-tabs for Overview, Event Log, and Logic. A filter bar shows various device categories like HOST DEVICE (1/1), PHYSICAL PORTS (0/13), DANTE PORTS (0/8), TRANSCEIVERS (2/12), and WIRELESS ENDPOINTS (4/4). The main content area is titled 'Host Device' and displays configuration for device ID 'ff080238'. It is organized into several columns: Network (Management), General, Version, Support Info, Dante, Network (AES67), PTP, Power, and Thermal. Each column contains specific status and configuration information.

## 9.9.5 Monitoring the Event Log

The Event Log provides useful information about events that happen in the system.

The Event Log can be filtered on:

- Time: default is 1 month prior to the current date and time
- Exceptions (warnings and errors): default is unchecked.

Events are sorted by data. Clicking the small blue arrow changes date order:

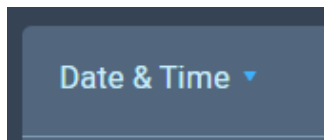

The **Level** column shows the status of data:

- Yellow triangle: warning
- Red circle with white cross: error
- No icon shown: this data is informational.

The following apply to the Event Log:

- The Event Log periodically refreshes but there is a **Refresh** button to pull the latest events
- The Event Log can be exported to a .csv file

- **Clear Event Log** clears current data. The data cannot be retrieved once it has been cleared
- Event logs are not stored permanently, only events since the last power or reboot cycle are available.

## 9.9.6 Monitoring the Logic Page (Status)

This page shows the GPIs and GPOs (relay) that you have set up in the **Configuration > Logic** page. You can see if these are currently active in the system under the **Status** column.

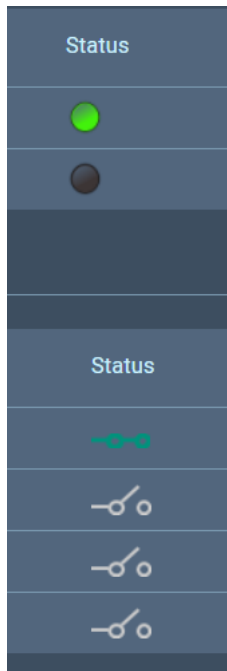

A green icon indicates a currently active input or relay.

### Forcing ON/OFF

The buttons under the FORCE column are toggle buttons that can be used to test the working of the GPIOs or to turn them permanently off or on. These override the working of the configured GPIOs.

Logic Inputs					
	GPI Label	Route Source	Route Destination	Status	Force
1	GPI1	No events assigned	No events assigned		<input type="button" value="OFF"/> <input type="button" value="ON"/>
2	GPI2	No events assigned	No events assigned		<input type="button" value="OFF"/> <input type="button" value="ON"/>

Logic Outputs					
	GPO Label	Key Target	On Behavior	Status	Force
1	GPO1	No triggers assigned	No triggers assigned		<input type="button" value="OFF"/> <input type="button" value="ON"/>
2	GPO2	No triggers assigned	No triggers assigned		<input type="button" value="OFF"/> <input type="button" value="ON"/>
3	GPO3	No triggers assigned	No triggers assigned		<input type="button" value="OFF"/> <input type="button" value="ON"/>

In this example, GPI 1 and GPO 2 are forced ON for testing purposes. GPO 2 is permanently OFF (for example, if you want to ensure that a signal light never comes on at this time).

# 10

## Security

---

This chapter describes important security features. It contains the following sections:

- 10.1 Warning .....110
- 10.2 Introduction ..... 110
- 10.3 Using Security Certificates .....111
- 10.4 Forcing HTTPS .....112

---

## 10.1 Warning

The CCM ensures that you do not turn off port 80 without testing your certificate. If you turn off port 80 without ensuring that you can reach the CCM using port 433 it is possible to get locked out of your CCM. If this happens, you must reset the Arcadia Central Station from the front panel menus. This will remove all configuration, including network details from your Arcadia Central Station.

**Note:** *Some knowledge of certificate authorization and HTTPS is needed when setting up a secure connection between a PC hosting the Core Configuration Manager (CCM) and a Arcadia Central Station.*

**Note:** *Each browser type (for example, Safari, Chrome, Edge, Firefox) uses its own method for certificate management. These methods can change with time and is beyond the control of Clear-Com. Please refer to the instructions supplied with your browser if you require more information.*

## 10.2 Introduction

The following are some of the main security features.

### 10.2.1 Secure HyperText Transfer Protocol (HTTPS)

HTTPS is an adaptation of the HTTP protocol. It protects against an intermediary being able to intercept data between devices, using data encryption and Public Key Cryptography to create a secured channel.

### 10.2.2 Using HTTPS With Your Arcadia Central Station

When using the CCM to establish your intercom setup, you might wish to protect your login credentials and configuration details from unauthorized interference. In this case you will establish an encrypted connection between the CCM and your Arcadia Central Station using the **Force HTTPS** feature.

### 10.2.3 The Force HTTPS Feature

The Arcadia Central Station uses port 80 (HTTP) and port 433 (HTTPS) for management. If you wish to create a secured route for data between the CCM and the Arcadia Central Station you must:

- Install a security certificate
- Turn off port 80, forcing traffic to use port 433

This creates a certified and encrypted connection between the Arcadia Central Station and the PC accessing the CCM.

## 10.3 Using Security Certificates

There are three types of security certificate available. Choose the certification option that best suits your security requirements:

- A certificate of your own choosing (full chain and private key)
- An EasyDNS authorized certificate for \*.clearcomdevices.com (this option requires you to register your Arcadia Central Station with a DNS server) and cannot be used unless your Arcadia Central Station has internet access
- The Clear-Com self-signed certificate

More detail about certificates:

1. **A certificate of your own choosing.** This option gives you complete control over the security of your Arcadia Central Station. This option requires specialized knowledge about how to obtain a fullchain certificate and private key, and how to install them on your browser. When using your own certificate you might have to provide a DNS server address and register the Arcadia Central Station.
2. **The EasyDNS certificate.** This is a commercial certificate. When using the EasyDNS certificate you have to have a DNS server address for Arcadia Central Station registration and a gateway for your device in order for the browser to verify the certificate with AlphaSSL and GlobalSign.
3. **The Clear-Com self-signed certificate (default).** This certificate can be used in a private network (does not require Internet access to verify the certificate). It can also be used to perform an initial test of your security setup. **Warning:** Browsers can be configured to trust the self-signed certificate, but this process will vary between browsers.

## 10.4 Forcing HTTPS

1. Chose and install a security certificate on the PC or browser used to reach the CCM of the Arcadia Central Station. Clear-Com offers a choice of 3 different types of certificate, offering different levels of security.
2. Test the certificate by trying to reach the CCM on the HTTPS port. Type: **HTTPS:// device IP address** in the browser URL field and press the [Enter] key.

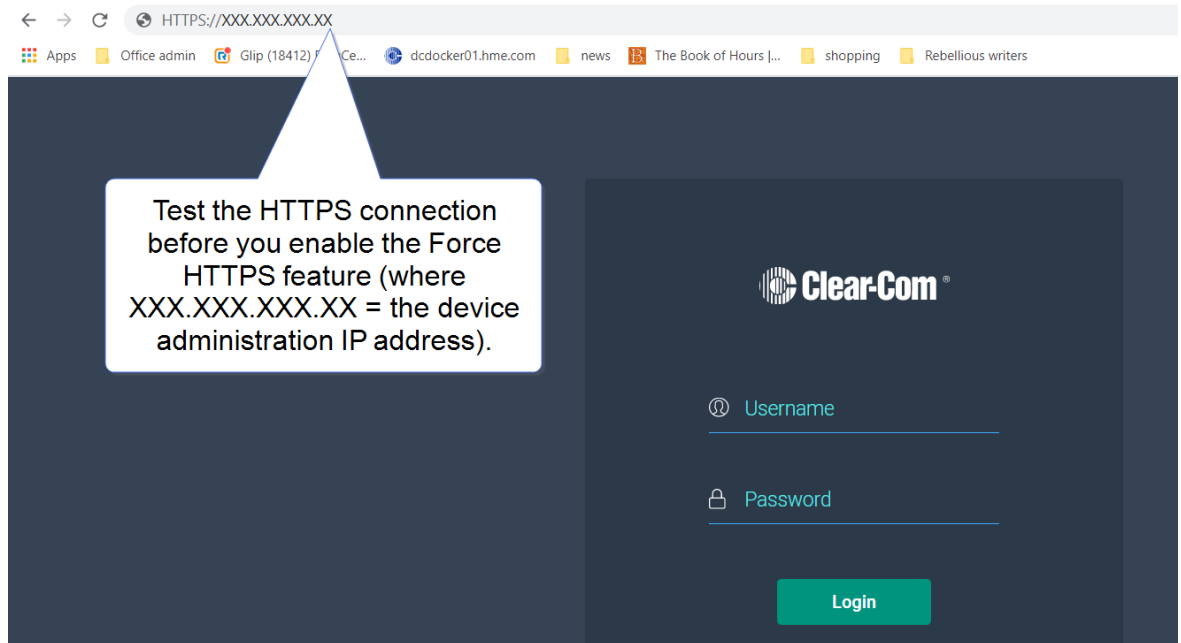

3. To enable **Force HTTPS** in the CCM navigate to: **Hardware > Resources > Host  > Security** and click to enable **Force HTTPS**. This turns port 80 off, forcing traffic to use port 433.



**ff080238** ×

Network Upgrade Wireless **Security**

### General

**i Info** PLEASE CONNECT USING HTTPS BEFORE FORCING HTTPS. THIS IS TO ENSURE YOU WON'T HAVE CERTIFICATE VALIDATION ISSUES.

Force HTTPS  Enabled  Disabled

### Default Certificate

The default certificate is used for internal traffic. Any other certificate loaded onto this unit will only be utilized for CCM.

**Regenerate**

Certificate Status	<b>Valid</b>
Certificate Type	<b>Self-signed</b>
Certificate Authority	<b>Clear-Com</b>
Expiration Date	<b>Jun 8 2023 --- 765 day(s) left.</b>
CA Certificate	<b>Download</b>

### Active Certificate

Use Default Certificate	<b>Switch</b>
Use EasyDNS Certificate	<b>Switch</b>
EasyDNS hostname	<b>cc-fsebase-312yf587-0.clearcomdevices.com</b>

# 11 Configuring from the Front Panel

This chapter describes how to configure the Arcadia Central Station from the front panel. It contains the following sections:

11.1 Introduction to Configuring from the Front Panel .....	115
11.2 Front Panel Menus .....	116
11.3 Passwords, Addresses and Reset to Default Settings .....	120

## 11.1 Introduction to Configuring from the Front Panel

Some common tasks you might perform from the front panel menus are:

- See/configure the Arcadia Central Station IP address
- See the default CCM password
- Null your 2-wire audio ports
- Reset the Arcadia Central Station to factory settings
- Reset the CCM password

To enter the Arcadia Central Station menu system, press the **Menu** button on the front panel. Navigate through the hierarchical menu using the rotary controllers. To select or commit a menu item, press the rotary encoder next to it.

To exit the menu system, press the Menu button again, or leave the device to time-out of menu mode (20 seconds).

## 11.2 Front Panel Menus

The front panel menu options are listed below.

### 11.2.1 Audio Settings

**Headset Limit.** This allows the user to set the headset limiter for the front panel headset.

- -12 dB to +8 dB/ OFF

#### **HS Mic Type**

- Dynamic (default)
- Electret

#### **Sidetone Gain**

- -15 dB to +8 dB (-12 dB default)

#### **Sidetone Control**

- Tracking (default)
- Non-Tracking
- Disabled

### 11.2.2 Host Settings

**Host Name.** Pushing the fourth rotary will open the on screen keyboard to allow the user to enter a new name for the device (touchscreen). [OK] when done.

#### **Display**

- Screen Brightness. High, Medium (default), Low, Very Low
- Screen Dimming. The screen will dim to Very Low when there is no activity. Timeout time: 1,2 (default),3,5,10 or 15 minutes.
- Touchscreen sensitivity: Low, Medium (default), High.

### 11.2.3 2W Audio (A,B)

Configure power settings for 2-wire audio sources and perform nulling.

- Interface - power settings
  - Power detected? Yes/No
  - Power Enabled/Disabled (default = disabled)
  - Mode Clear-Com/RTS (default = Clear-Com)
- Nulling: 2W A and 2W B. Press the rotary control (Start) to perform a null. Nulling is only available if power is detected.

### 11.2.4 2W Audio (C,D)

See 2W Audio (A,B)

### 11.2.5 Discovery

- Discover FSII TCVR.
  - Lists all FSII transceivers visible on the network. Select the transceiver you wish to register (third rotary). Select **Register** and push the rotary (fourth rotary) to begin the connection sequence.
- Discover FSE TCVR.
  - Lists all FS Edge transceivers visible on the network. Select the transceiver you wish to register (third rotary). Select **Register** and push the rotary (fourth rotary) to begin the connection sequence.

**Deregister** will remove the transceiver from the system. You will only see the **Deregister** option if the transceiver has been already registered.

### 11.2.6 Transceiver

Lists all registered transceivers. You can view and edit **Label** and **Cable Comp (E1 only)** here. Pushing the fourth rotary will open the onscreen keyboard (touchscreen). [OK] when done.

- FSII IP. Version, Label.
- FS Edge. Version, Label.
- FSII E1. Version , Label, Cable Comp.

## 11.2.7 Networking

Configure and view:

- LAN Port Assignment
- DHCP Enabled/Disabled
- IP Address (read only when DHCP is Enabled)
- Subnet Mask (read only when DHCP is Enabled)
- MAC Address (read only)

Push the fourth rotary to open the on screen touchscreen keyboard to change IP and Subnet. [OK] when done. The keyboard is only available when DHCP is disabled.

**Note:** *When changing from DHCP **Enabled** to DHCP **Disabled**, the address previously assigned by the DHCP server will be set as the static address. This can cause IP conflicts so you must change the address to one not provisioned by the DHCP server.*

## 11.2.8 AES67 (for IP transceivers)

The section of the menu is read only and only shown if the AES67 connection has been configured with a LAN port from the CCM. It shows:

- LAN Port Assignment
- DHCP Enabled/Disabled
- IP Address
- Subnet Mask
- MAC Address

**Note:** *When changing from DHCP **Enabled** to DHCP **Disabled**, the address previously assigned by the DHCP server will be set as the static address. This is can cause IP conflicts, so you must change the address to one not provisioned by the DHCP server.*

## 11.2.9 Administration

- Beltpacks
  - Over the Air: Press rotary four to **Start OTA**. Put the Arcadia Central Station in pairing mode for OTA registration of beltpacks (600 seconds).
  - BP Role List Sorting:

- Role Number
- Alphabetical
- Battery type: use this setting if the beltpacks are not using the supplied Li-ion batteries.
  - Alkaline (default)
  - NiMh (for use in high pressure environments)
- Software
  - Current version
  - Update software from a file on a USB (insert into USB C on front of Arcadia Central Station)
- License (you will not see this menu item on a FreeSpeak Edge Base)
  - Connections - current connected ports on this Arcadia Central Station
  - Licensed Ports
- Reset
  - Reboot
  - Reset to Default. Reset here will reset role, channel and network details. You will need to **Add** your transceivers back into the system after reset.
  - Reset CCM Password
- Support Info
- Settings
  - Save
  - Restore
- CCM Access
  - Username
  - Default password
- Hardware (view only)
  - Electronic main board serial number

## 11.3 Passwords, Addresses and Reset to Default Settings

You can find the Arcadia Central Station IP address, manage the CCM password and reset to default settings.

### 11.3.1 Find the Arcadia Central Station IP Address

1. Press the **Menu** button on the front of the Arcadia Central Station.
2. Navigate to **Networking > Management > IP Address** using the rotary controllers.
3. You will see the device IP address.



### 11.3.2 Find the default password for the CCM

1. Press the **Menu** button on the front of the Arcadia Central Station.
2. Navigate to **Administration > CCM Access > Default Password** using the rotary controllers.
3. You will see the default password in the right hand menu screen.





### 11.3.3 Reset the device to default settings

1. Press the **Menu** button on the front of the Arcadia Central Station.
2. Navigate to **Administration > Reset > Reset To Default > Reset Base**.
3. The Arcadia Central Station will reset to factory settings.

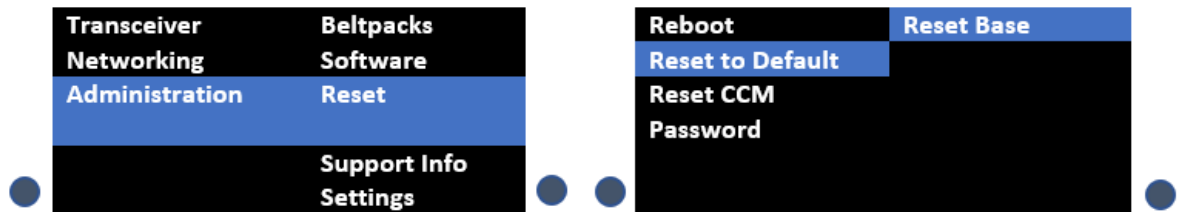

**Note:** When resetting the Arcadia Central Station to default settings using the front panel menu system, all the system configuration details, including network settings are reset. When resetting to default from the CCM, the network settings are NOT reset.

**Note:** When you reset the Arcadia Central Station to default settings, you must **Add** the transceivers to the system again. See [Adding IP Transceivers \(FS Edge, FS II 1.9\)](#) on page 79.

### 11.3.4 Reset the CCM password

1. Press the **Menu** button on the front of the Arcadia Central Station.
2. Using the right hand rotary controller select **Administration > Reset > Reset CCM Pass**.
3. Press the right hand rotary controller.
4. The password will reset to its default setting.

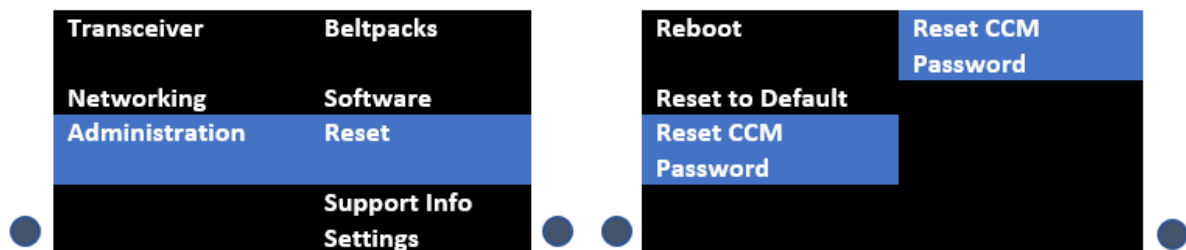

# 12 Upgrading Firmware

---

This chapter describes how to upgrade the firmware on your Station. It contains the following sections:

12.1 Introduction .....	123
12.2 Upgrading using the CCM .....	123
12.3 Upgrading using a USB stick .....	123

---

## 12.1 Introduction

There are two ways to upgrade the firmware on the Arcadia Central Station:

- Using the CCM web interface. When upgrading from the CCM, you can upgrade all connected resources (for example, transceivers and beltpacks).
- Using a USB stick (USB A on the front of the Arcadia Central Station). When upgrading in this way, only the Arcadia Central Station can be upgraded.

Device to upgrade	File extension
Arcadia Central Station, FS II IP TCVR, FS Edge IP TCVR	.ccf
FS II beltpack, FS II E1 TCVR	.fww
FS Edge beltpack	.ccu

## 12.2 Upgrading using the CCM

1. In the CCM, navigate to **Hardware > Hosts (click anywhere on the Hosts panel) > Upgrade**.
2. Press **Select File** and select the file containing the updated firmware.
3. When the file is uploaded, the **Upgrade** button will be enabled.
4. Press the **Upgrade** button.
5. The upgrade process will start and the Arcadia Central Station will reboot before being available again.
6. The new version of the firmware will be displayed in the **Hosts** panel.

## 12.3 Upgrading using a USB stick

1. Copy the firmware file (.ccf) onto a USB stick. The file must be at the top level of the USB drive, not within any folders.
2. Insert the USB into the USB port on the front of the Arcadia Central Station.
3. Press the **Menu** button.
4. Using the rotary controllers, navigate to **Administration > Software > Update**.
5. The display will show the available firmware files stored on the USB. Select the one you require.
6. Press the 4th rotary encoder. The unit will upgrade and then reboot.

7. To check the current firmware version, in the menu system navigate to **Administration > Software > Current**. The current software version is displayed in the 4th menu screen.

## 13 Spare parts

Part	Part Number
External power supply, 12VDC 150W	PSU-EXT-0001
Split cable, RJ45 to PGM and SA	CAB-RJ45-PGM-SA
Ethernet fiber modules*: <ul style="list-style-type: none"> <li>• 1 Gbps SM SXFIBER SFP</li> <li>• 1 Gbps MM LXFIBER SFP</li> </ul>	<ul style="list-style-type: none"> <li>• SFP-SMFO-1G-LX</li> <li>• SFP-MMFO-1G-SX</li> </ul>
E1 fiber modules* <ul style="list-style-type: none"> <li>• Proprietary, based on E1: SM</li> <li>• Proprietary, based on E1: MM</li> </ul>	<ul style="list-style-type: none"> <li>• HLI-SMFO</li> <li>• HLI-MMFO</li> </ul>
Fan plate assembly	T40020-1
Rack ear (x1)	272G162
PSU Mounting Bracket	272G048
Encoder cap (x1)	272G286
Arcadia Central Station User Guide	PUB-00021

\*There is a detailed list of all Clear-Com SFPs (including range, wavelength and speed) on the [FreeSpeak II Knowledge Center](#).

# 14 Front Panel Menu Reference Tables

---

This chapter lists the front panel menu options. It contains the following sections:

- 14.1 Audio Settings ..... 127
- 14.2 Host Settings ..... 127
- 14.3 2 W Audio (A/B) (C/D) ..... 128
- 14.4 Discovery ..... 128
- 14.5 Transceiver ..... 129
- 14.6 Networking ..... 130
- 14.7 Administration ..... 131

---

**Note:** Default values are shown in **bold**.

## 14.1 Audio Settings

Level 1	Level 2	Level 3	Level 4
Audio	Headset	Headset Limit	8 to -12 dB/Off Default = 0 dB
		Headset detect	<b>Enabled</b> /Disabled
		HS Mic Type	Electret/ <b>Dynamic</b>
		Sidetone Gain	8 to -15 dB Default = -12
		Sidetone Control	<b>Tracking</b> /Non-Tracking/Disabled

## 14.2 Host Settings

Level 1	Level 2	Level 3	Level 4
Host Settings	Host name	Edit	Press controller 4 to open a touchscreen keyboard.
	Display	Screen Brightness	High/ <b>Medium</b> /Low/Very Low
		Screen Dimming	1 to 15 minutes Default = 2 minutes
		Touchscreen sensitivity	Low, <b>Medium</b> , High

### 14.3 2 W Audio (A/B) (C/D)

Level 1	Level 2	Level 3	Level 4
2W Audio (A / B)	Interface	Power detected	Yes/No
		Power	Enabled/ <b>Disabled</b>
		Mode	<b>Clear-Com</b> /RTS
	2W A	Nulling	The nulling function is only available if power is detected.
	2W B	Nulling	as above
Audio (B / C)	Same as Audio (A / B)		

### 14.4 Discovery

Level 1	Level 2	Level 3	Level 4
Discovery	Discover FSII TCVR	Discovered FSII TCVRs	Register/Unregister
	Discover FSE TCVR	Discovered FSE TCVRs	Register/Unregister



## 14.5 Transceiver

Level 1	Level 2	Level 3	Level 4
Transceiver	TCVR 1 ... XX View configured transceivers. Max: <ul style="list-style-type: none"> <li>• E1; 10</li> <li>• IP TCVRs; 6</li> </ul>	Version	
		Label	
		Cable Comp (E1 only)	<b>0 - 69 m</b> , 70 - 139 m, 140 - 209 m, 210 - 279 m, 280 - 349 m, ... (increments of 70 m) up to 1540 - 1609 m

## 14.6 Networking

Level 1	Level 2	Level 3	Level 4
Networking	Management	LAN Status	Up/Down
		LAN Port	LAN Ports 1 - 4
		DHCP	<b>Enabled/Disabled</b>
		IP Address	
		Subnet mask	
		MAC	
	AES67 (only visible if AES67 has been configured to its own LAN)	LAN Status	Up/Down
	Dante (only visible if Dante has been configured in the CCM)		
		LAN Port	By default management and AES67 are configured to LAN 1. This can be changed in the CCM.
		DHCP	Enabled/Disabled
		IP Address	
		Subnet mask	
		MAC	MAC address

14.7 Administration

Level 1	Level 2	Level 3	Level 4
Administration	Beltpacks	Over The Air	Start OTA
		BP Role List Sorting	Sort by <b>Role Number</b> /Alphabetical
		Battery Type	<b>Alkaline</b> /NiMh (for use when not using the supplied Li-ion type batteries)
	Software	Current	View current version
		Update	Use this to update the Arcadia Central Station using a USB stick.
	License	Connections	View connected ports
		Licensed Ports	View licensed ports: <ul style="list-style-type: none"> <li>• Total Ports</li> <li>• Wireless Ports</li> <li>• Dante Ports</li> <li>• Any Ports</li> </ul>
	Reset	Reboot	Press rotary 4 to reboot now

Level 1	Level 2	Level 3	Level 4
		Reset to Default	Reset Base. When you reset the Base here, as well as system setup details (channels and roles), network details (IP addresses) are also reset. This is not the case when resetting the Base in the CCM. After resetting you must Add transceivers again.
		Reset CCM Password	Press rotary 4 to reset CCM password to the default setting.
	Support Info	Generate	Insert USB
	Settings	Save Restore	Insert USB
	CCM Access	Username Default password	
	Hardware	Hw Info Hw Version BOM number PCB number Serial number Product number	

# 15 Specifications

---

This section contains a list of technical specifications for the Station. It contains the following subsections:

- 15.1 Arcadia Central Station ..... 134
- 15.2 Capacity ..... 137
- 15.3 Frequency Response - Station to Beltpack ..... 137
- 15.4 Front Panel Headset Microphone ..... 138
- 15.5 Network Specifications ..... 139

---

## 15.1 Arcadia Central Station

Specification	Value
Front panel headset	(1) 4-pin XLR-M or 5-pin XLR-M <ul style="list-style-type: none"> <li>• auto headset detect</li> </ul>
Gooseneck microphone input	<ul style="list-style-type: none"> <li>• Input type: Dynamic, Electret (selectable)</li> <li>• Frequency Response: Gooseneck Mic - Partyline: 200Hz – 12kHz + 3dBu</li> <li>• Frequency Response: Gooseneck Mic - Line Out: 200Hz – 20kHz + 3dBu</li> <li>• Mic Limiter Threshold: -35dBu ±3dB</li> <li>• Mic Limiter Range: ≥ 20dB</li> <li>• Max Input Level: -10dBu</li> <li>• Input Level: -45dBu nominal; -10dBu MAX</li> <li>• Headset Mic Voltage: 5V (Electret selectable)</li> </ul>
Speaker Output	<ul style="list-style-type: none"> <li>• Speaker Type: 1.6 x 2.8in oval</li> <li>• Load Impedance: 4Ω</li> <li>• Max Output Level before 1% Distortion: 18dBu ± 2dB</li> <li>• Total Harmonic Distortion (THD): &lt; 0.5% THD at 1kHz</li> <li>• Max Speaker Level: 87dB ± 2dB SPL A Weighted at 3ft</li> <li>• Frequency Response: 100Hz – 10kHz ± 9dB</li> </ul>
USB connector	USB type A
Front panel buttons	<ul style="list-style-type: none"> <li>• MIC: Microphone ON/OFF button</li> <li>• Menu button</li> <li>• HDST: Headset ON/OFF button</li> <li>• Fn: Function button (not active)</li> </ul>
Front panel rotary encoders	(5) Digital rotary encoders Operating level: 0dBu to + 18dBu, nominal, or -18dBu to +8dBu

Specification	Value
Front panel touch screens	(2) 480 x 128 color TFT LED Touch Screen displays
Status LEDs	(2) Power supply status LEDs, (1) Arcadia Central Station status LED, (1) Volume level three color control LED array
The Arcadia Central Station has two power supplies which can be used together to provide power redundancy.	
Power	<ol style="list-style-type: none"> <li>1. AC Mains input: 100-240V AC, 50-60Hz, 160W Max, IEC60320 C14 inlet.</li> <li>2. DC Low Voltage Input: 12V DC +/- 5%, 12A External</li> </ol> <p>(1) AC/DC Power Supply with sleeve locking connector (<b>PSU-EXT-001 supplied</b>): Input: 100-240V AC, 50-60Hz, 2.2A Max, Output: 12V DC +/- 5%, 12.5A, IEC60320 C14 inlet</p>
GPIO port	<p>(2) DB9</p> <ul style="list-style-type: none"> <li>• Relay contact type: SPDT</li> <li>• Relay quantity: 4</li> <li>• Relay contact voltage rating: 30 VDC</li> <li>• Relay contact current rating: 1 A</li> <li>• Input type: Opto-Isolated</li> <li>• Input quantity: 2</li> <li>• Input voltage range: 4 - 30 volts DC or AC</li> <li>• Input current: &gt;=1.2mA required</li> </ul>

Specification	Value
2-wire I/O	<p>(4) XLR-3F</p> <ul style="list-style-type: none"> <li>• 2-wire I/O: Selectable RTS or Clear-Com mode, software controlled null, null depth &gt;60dB at 1kHz</li> <li>• 2-wire Power On/Off: A/B, C/D paired- software controlled</li> <li>• 2-wire Output Voltage: 25 – 28 VDC, 560 mA per pair (A/B or C/D)</li> <li>• 2-wire Impedance: &gt;10kΩ</li> <li>• 2-wire Operating Levels: -18dBu nominal (Clear-Com Mode), -12dBu nominal (RTS Mode), Headroom 18dB</li> <li>• 2-wire Frequency Response: 200 to 12kHz. ±3dB</li> <li>• 2-wire Total Harmonic Distortion (THD): &lt; 0.1% THD at 1 kHz</li> </ul>
4-wire I/O	<p>(8) RJ45</p> <ul style="list-style-type: none"> <li>• 4-wire I/O: Output Impedance &gt;10kΩ, Input Impedance 200Ω + 10%, transformer isolated balanced input and output.</li> <li>• 4-wire Operating Levels: 0dBu Nominal, 18dBu headroom</li> <li>• Port 8 used for stage announce and program feed</li> </ul>
Stage announce and program feed	<p>(1) Cable assembly <b>CAB-RJ45-PGM-SA provided.</b></p> <p>Connects to RJ45 (port 8 on the Station) - transformer isolated, line-level input, independent.</p> <ul style="list-style-type: none"> <li>• XLR-3F labeled PGM input</li> <li>• XLR-3M labeled SA output</li> </ul> <p>Program Input level control via rotary encoder.</p>
Sync IN/OUT	(2) RJ45 sync input and output
E1 Splitter/transceiver ports	<p>(2) RJ45</p> <p>(2) Fiber, to be used with SFP module</p> <p><b>Note:</b> only 2 splitter ports active at any one time and these must both be EITHER RJ45 OR Fiber.</p>



Specification	Value
LAN connectors	(2) RJJ45 (2) Fiber, to be used with SFP module All 4 LAN ports are fully user configurable, to be split between management, AES67 and Dante traffic.
Dimensions	1 RU: h.44 x w.483 x d. 355 mm (1.75 x 19 x 14 inches)
Weight	Approx 3.3 kg (7.25 lb)

## 15.2 Capacity

Specification	Value
Number of transceivers supported by Arcadia Central Station	26 in total <ul style="list-style-type: none"> <li>• 16 IP transceivers (FreeSpeak II or FreeSpeak Edge)</li> <li>• E1 transceivers, 2 connected directly to the Arcadia Central Station, 10 via a splitter</li> </ul>
Number of FreeSpeak belt packs per Arcadia Central Station	Up to 32 belt packs in total, made up of either FreeSpeak II or FreeSpeak Edge belt packs
Audio Channels	Max 100
Groups	Max 100
GPIOs	Input Quantity: 2

## 15.3 Frequency Response - Station to Belt pack

Specification	Value
Arcadia Central Station to belt pack frequency response	<ul style="list-style-type: none"> <li>• FreeSpeak II belt packs: 200 Hz - 7.5 kHz</li> <li>• FreeSpeak Edge belt packs: 200 Hz - 12 kHz</li> </ul>

## 15.4 Front Panel Headset Microphone

Specification	Value
Headset microphone input	<ul style="list-style-type: none"> <li>• Input type: Dynamic /Electret - Selectable</li> <li>• Frequency response: headset mic - Partyline: 200Hz – 12 kHz + 3dBu</li> <li>• Frequency response: headset mic - Line Out: 200Hz – 20 kHz + 3dBu</li> <li>• Mic limiter threshold: -50dBu ±3dB</li> <li>• Mic limiter range: ≥ 20dB</li> <li>• Max input level: -25dBu</li> <li>• Input level: -60dBu nominal; -25dBu MAX</li> <li>• Headset mic voltage 5V (Electret selectable)</li> </ul>
Headset microphone output	<ul style="list-style-type: none"> <li>• Load Impedance: &gt; 32Ω</li> <li>• Output Impedance: 33Ω</li> <li>• Max Output Level before Distortion: &gt;13 dBu</li> <li>• Total Harmonic Distortion (THD): &lt; 0.1% THD at 1 kHz</li> <li>• Headset Mic - Partyline: -78 dBu (Clear-Com mode)</li> <li>• Headset Mic - Line Out: -60 dBu</li> <li>• Frequency Response: Partyline - Headset Out: 200Hz – 10 kHz + 3dBu</li> </ul>

## 15.5 Network Specifications

Specification	Value
AoIP Interface Protocols	<ul style="list-style-type: none"> <li>• RTSP/SAP</li> <li>• AES67</li> <li>• Dante</li> </ul>
Audio Sampling	24-bit Linear 48KHz
IP Addressing	<ul style="list-style-type: none"> <li>• Static</li> <li>• DHCP</li> </ul>
Network Compatibility	Layer 2 and Layer 3 only
Quality of Service	DiffServ RFC2474
IGMP	On (AoIP)
Multicast	On (AoIP)
Network Timing	PTPv2 (AoIP)/PTPv1 (Dante)
Perduplex Connection	<ul style="list-style-type: none"> <li>• 1 x FS II IPT bandwidth usage: ~7 Mbps</li> <li>• 1 x FS Edge IPT: ~9.6 Mbps</li> </ul>
Network Protocols	<ul style="list-style-type: none"> <li>• Ethernet IPv4 Unicast Audio and Control</li> <li>• mDNS-Multicast Device Discovery</li> </ul>
Network Ports	<ul style="list-style-type: none"> <li>• Unicast:</li> <li>• Port 80 TCP - Web Interface, System Management, Expansion</li> <li>• Port 443 for HTTPS</li> <li>• Port 6001 UDP - AES67 Data</li> <li>• Port 15000 - 15256 UDP - AES67 Audio</li> </ul>
	<p>Multicast:</p> <p>Port 5353 UDP - mDNS, Names, Discovery, Linking, Expansion, Dante (through various ports)</p>

Specification	Value	
Network Jitter Tolerance	< 1µs required for RF Syncing of Transceivers	
Recommended Ethernet Switches	<ul style="list-style-type: none"> <li>• Managed Ethernet Switch - Layer 3</li> <li>• 100/1000 Base - T ports for endpoints</li> <li>• 1000 Base IP Trunks between switches</li> <li>• QoS Configuration</li> <li>• Energy Efficient Ethernet bypass option</li> <li>• IGMP Snooping bypass option</li> </ul>	
QoS Tags for AoIP		
Clock	IEEE 1588-2008 Announce, Synch, Follow_Up, Delay_Req, Delay_Resp, Pdelay_Req, Pdelay_Resp and Pdelay_Resp_Follow_Up packets	EF (46) (Expedited Forwarding)
Media	RTP and RTCP media stream data	AF41 (34) (Assured Forwarding)
Best Effort	IEEE 1588-2008 signaling and management messages. Discovery and connection management messages.	DF (0) (Default Forwarding)
QoS Tags for Dante		
High	Time Critical PTP Events	CS7 (56)
Medium	Audio, PTP	EF (46) (Expedited Forwarding)
Low	Reserved	CS1 (8)
None	Other Traffic	Best Effort (0)

# 16 Pinouts

---

This chapter describes the pinouts of the connectors on the Arcadia Central Station. It contains the following sections:

- 16.1 GPIO pinouts ..... 142
- 16.2 2-Wire Pinouts ..... 143
- 16.3 4-Wire Pinouts ..... 144
- 16.4 DECT Sync ..... 144

---

# 16.1 GPIO pinouts

## GPIO 1 (Relay 1 &2)

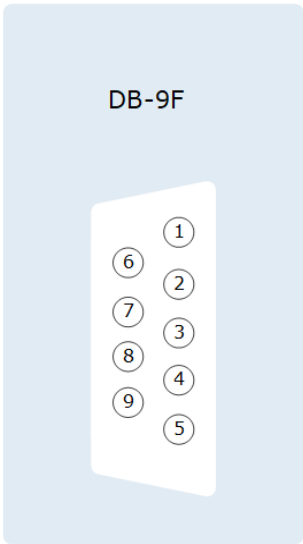

- 1. Relay 1 Common
- 2. Relay 1 Normally Closed
- 3. Relay 1 Normally open
- 6. Relay 2 Common
- 7. Relay 2 Normally Closed
- 8. Relay 2 Normally Open
- 4. Input A1
- 5. Input B1
- 9. 12V

Shield 0V

## GPIO 2 (Relay 3 & 4)

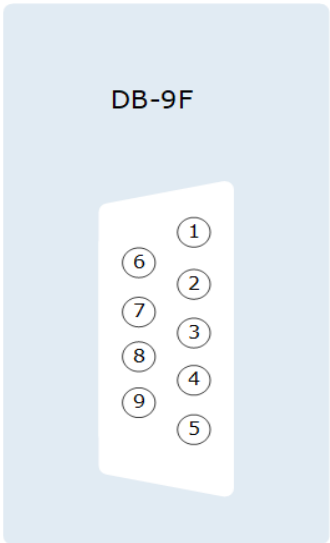

- 1. Relay 3 Common
- 2. Relay 3 Normally Closed
- 3. Relay 3 Normally open
- 6. Relay 4 Common
- 7. Relay 4 Normally Closed
- 8. Relay 4 Normally Open
- 4. Input A2
- 5. Input B2
- 9. 12V

Shield 0V

## Suggested wiring for a footswitch

From	To	
GPIO-DB9 pin 4 (input A1)	GPIO-DB9 pin 9 (+12V)	link (jumper) wire
GPIO-DB9 pin 5 (input B1)	footswitch	
GPIO-DB9 Shell (0V)	footswitch	

16.2 2-Wire Pinouts

16.2.1 Clear-Com 2-Wire XLR Pinout

- 1. Ground
- 2. DC power (30V)
- 3. Duplex audio

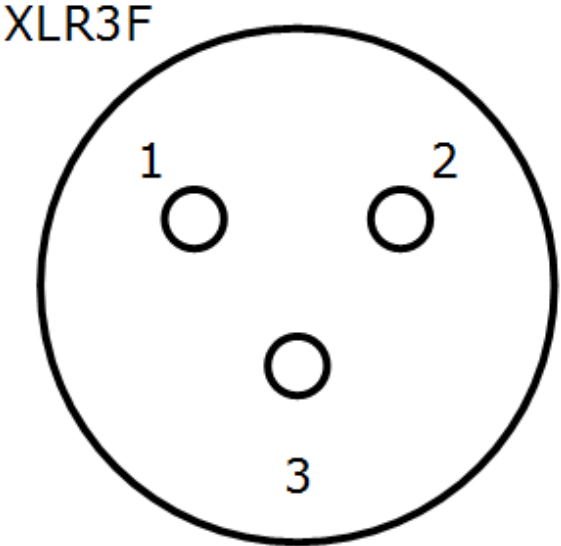

16.2.2 RTS 2-Wire XLR pinout

- 1. Ground
- 2. DC power (30V)  
Duplex audio 1
- 3. Duplex audio 2

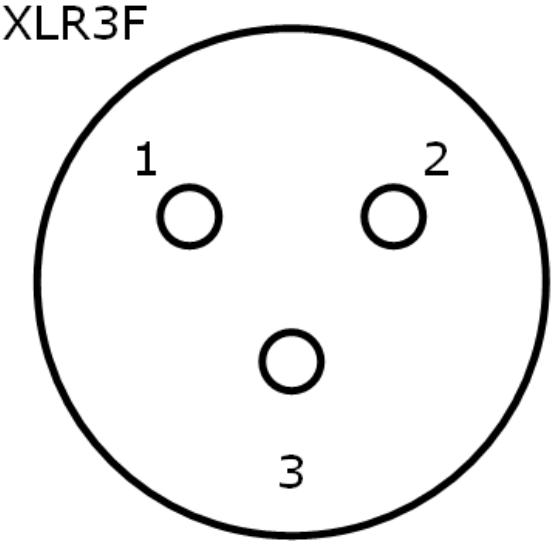

## 16.3 4-Wire Pinouts

Pin	4-wire	4-wire-X (default)
1	Data in +	Data out +
2	Data in -	Data out -
3	Audio in +	Audio out +
4	Audio out +	Audio in +
5	Audio out -	Audio in -
6	Audio in -	Audio out -
7	Data out +	Data in +
8	Data out -	Data in -

## 16.4 DECT Sync

Pin	Sync In	Sync Out
Pin 1	DECTSYNC IN +	DECTSYNC OUT +
Pin 2	DECTSYNC IN -	DECTSYNC OUT -
Pin 3	8 KHZ IN +	8 KHZ OUT +
Pin 6	8 KHZ IN -	8 KHZ OUT -

### Caution: Shielded Cable Requirement

Shielded Cable is required for ALL FreeSpeak GPIO Port connectivity. CAT 5e Shielded Cable must be used to assure compliance with domestic and international emissions standards. Customers, Installers and or qualified Personnel failing to use shielded cables may cause radio interference in which case the user may be required to take adequate measures.



## 17 Regulatory Compliance (Regulatory Model: 1410)

Applicant Name: Clear-Com LLC

Applicant Address: 1301 Marina Village Pkwy, Suite 105, Alameda CA 94501, United States

Manufacturer Name: Clear-Com LLC

Manufacturer Address: 1301 Marina Village Pkwy, Suite 105, Alameda CA 94501, United States

Country of Origin: USA

Brand: Clear-Com

**Caution:** All products are compliant with regulatory requirements detailed in this document when the user follows all installation instructions and operating conditions per Clear-Com specifications

**Caution:** Use of accessories and peripherals other than those recommended by Clear-Com may void the product's compliance as well as the user's authority to operate the equipment.

### 17.1 FCC Notice

This device complies with Part 15 of the FCC rules. Operation is subject to the following two conditions: (1) This device may not cause harmful interference, and (2) This device must accept any interference received, including interference that may cause undesired operation.

**NOTE:** This equipment has been tested and found to comply with the limits for a Class A digital device, pursuant to Part 15 of the FCC rules. These limits are designed to provide reasonable protection against harmful interference when the equipment is operated in a commercial environment. This equipment generates, uses and can radiate radio frequency energy and, if not installed and used in accordance with the instruction manual, may cause harmful interference to radio communication. Operation of this equipment in a residential area is likely to cause harmful interference, in which case the user will be required to correct the interference at his own expense.

Changes or modifications not expressly approved by Clear-Com, LLC, an HM Electronics, Inc. company could void the user's authority to operate this equipment.

## 17.2 FCC/IC/EC RF Exposure Warning

- This product complies with FCC/IC/EC radiation exposure limits set forth for an uncontrolled environment.
- Produits Clear-Com sont conformes aux limites IC d'exposition aux rayonnements définies pour un environnement non contrôlé.
- This product may not be co-located or operated in conjunction with any other transceiver or transmitter.
- Ce produit ne peut pas être co-localisé ou utilisé en conjonction avec un autre émetteur-récepteur ou émetteur.
- To comply with FCC/IC/EC RF exposure requirements, the Antenna/Transceiver unit must be installed and operated at least 20 cm (8 inches) from any person.
- Produits Clear-Com doivent être installés et utilisés avec distance minimum de 20cm entre le radiateur et votre corps.

## 17.3 Industry Canada Compliance Statement

This Class[A] digital device complies with Canadian ICES-003.

Avis de conformité à la réglementation d'Industrie Canada

Cet appareil est conforme aux CNR d'Industrie Canada applicables aux appareils radio exempts de licence. L'exploitation est soumise aux deux conditions suivantes:

(1) cet appareil ne doit pas provoquer d'interférence, et

(2) cet appareil doit accepter toute interférence radioélectrique subie, même si l'interférence est susceptible d'en compromettre le fonctionnement.

Cet émetteur exempt de licence est équipé d'une antenne intégrée. Cet émetteur exempt de licence n'est pas autorisé à fonctionner avec une autre antenne.

Cet appareil numérique de la class[\*] est conforme à la norme NMB-003 du Canada.

## 17.4 Korean Notice

A급 기기 (업무용 방송통신기자재)

이 기기는 업무용(A급)으로 전자파적합기기로서 판매자 또는 사용자는 이 점을 주의하시기 바라며, 가정외의 지역에서 사용하는 것을 목적으로 합니다.

## 17.5 European Union (CE mark)

The CE marking indicates compliance with the following directives and standards, whenever applicable to the product in question.

**Directives:**

- Radio Equipment Directive 2014/53/EU
- Electromagnetic Compatibility Directive 2014/30/EU
- Low Voltage Directive 2014/35/EU
- RoHS Directive 2011/65/EU, 2015/863/EU

**Standards:**

- EN55032
- EN55035
- IEC/EN62368-1
- EN300328
- EN301489
- EN50581



## 17.6 United Kingdom (UKCA Mark)

The UKCA (UK Conformity Assessed) marking is a new UK product marking that will be used for goods being placed on the market in Great Britain (England, Wales and Scotland). The UKCA marking alone cannot be used for goods placed on the Northern Ireland market, which require the CE marking or UK(NI) marking.



**Warning:**

This is a Class A product. In a domestic environment this product may cause radio interference in which case the user may be required to take adequate measures.

## 17.7 Electrical and Electronic Equipment (WEEE) Waste

The European Union (EU) WEEE Directive (2012/19/EU) places an obligation on producers (manufacturers, distributors and/or retailers) to take-back electronic products at the end of their useful life. The WEEE Directive covers most Clear-Com products being sold into the EU as of August 13, 2005. Manufacturers, distributors and retailers are obliged to finance the costs of recovery from municipal collection points, reuse, and recycling of specified percentages per the WEEE requirements.

### Instructions for Disposal of WEEE by Users in the European Union

The symbol shown below is on the product or on its packaging which indicates that this product was put on the market after August 13, 2005 and must not be disposed of with other waste. Instead, it is the user's responsibility to dispose of the user's waste equipment by handing it over to a designated collection point for the recycling of WEEE. The separate collection and recycling of waste equipment at the time of disposal will help to conserve natural resources and ensure that it is recycled in a manner that protects human health and the environment. For more information about where you can drop off your waste equipment for recycling, please contact your local authority, your household waste disposal service or the seller from whom you purchased the product.

